



Original Operating Manual

For professional use.
Always follow the information in this manual,
particularly the safety instructions and the warning
instructions. Store the manual in a safe place.

Version 07/2017

PROTEC GM 1-350

PROTEC GM 1-530

Airless manual gun

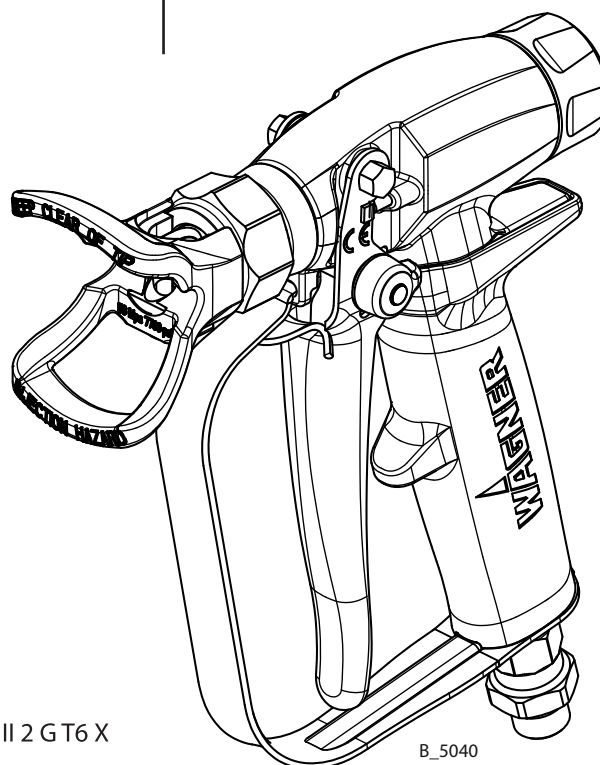

UK
PK  II 2 GT6 X

B_5040

Contents

1	ABOUT THESE INSTRUCTIONS	4
1.1	Preface	4
1.2	Warnings, Notices and Symbols in these Instructions	4
1.3	Languages	5
1.4	Abbreviations	5
1.5	Terminology for the Purpose of this Manual	5
2	CORRECT USE	6
2.1	Device type	6
2.2	Type of Use	6
2.3	For Use in Potentially Explosive Areas	6
2.4	Processible Working Materials	6
2.5	Misuse	6
3	IDENTIFICATION	7
3.1	Explosion protection identification	7
3.2	Identification "X"	7
3.3	Use in areas subject to explosion hazards	7
3.4	Example Type Plate: PROTEC GM 1-530	8
4	BASIC SAFETY INSTRUCTIONS	8
4.1	Safety instructions for the operator	8
4.2	Safety instructions for staff	9
5	DESCRIPTION	14
5.1	Components	14
5.2	Mode of operation	14
5.3	Safety fixtures	14
5.4	Included items	15
5.5	Data	15
6	ASSEMBLY AND COMMISSIONING	16
6.1	Training of Assembly/Commissioning Staff	16
6.2	Storage conditions	16
6.3	Typical Airless Spraying System	16
6.4	Grounding	17
6.5	Lacquer Preparations	17
6.6	Commissioning	17
7	OPERATION	19
7.1	Training the operating staff	19
7.2	Work	19
8	CLEANING AND MAINTENANCE	23
8.1	Cleaning	23
8.2	Maintenance	24
9	TROUBLESHOOTING	28
10	REPAIR WORK	29
10.1	Repair Staff	29
11	DISPOSAL	29

12	ACCESSORIES	30
12.1	Nozzle for nozzle holder PT-HD GM1	30
12.2	Nozzle for nozzle holder WAGNER Tip 7/8 UNF	31
12.3	Nozzle for anti-contact guard 7/8 UNF	31
13	SPARE PARTS	32
13.1	How to order spare parts?	32
13.2	Spare Parts List PROTEC GM 1-350/530	33
14	DECLARATION OF CONFORMITY	35

1 ABOUT THESE INSTRUCTIONS

1.1 PREFACE

The operating manual contains information about safely operating, maintaining, cleaning and repairing the device.





The operating manual is part of the device and must be available to the operating and service personnel.

The device may only be operated by trained personnel and in compliance with this operating manual.

Operating and service personnel should be instructed according to the safety instructions. This equipment can be dangerous if it is not operated according to the instructions in this operating manual.

1.2 WARNINGS, NOTICES AND SYMBOLS IN THESE INSTRUCTIONS

Warning instructions in this operating manual highlight particular dangers to users and to the device and state measures for avoiding the hazard. These warning instructions fall into the following categories:

 DANGER	Immediate risk of danger. Non-observance will result in death or serious injury.
 WARNING	Potential risk. Non-observance may result in death or serious injury.
 CAUTION	Potentially hazardous situation. Non-observance may result in minor injury.
 NOTICE	Potentially hazardous situation. Non-observance may result in damage to property.
Note	Provides information about particular characteristics and how to proceed.

Explanation of warning:**⚠ LEVEL OF DANGER****This notice warns you of a hazard!**

Possible consequences of not observing the warning instructions.

→ The measures for preventing the hazard and its consequences.

**1.3 LANGUAGES**

The operating manual is available in the following languages:

Language	Order No.
English	2439572

Supplement for WAGNER Tip nozzle holder:

Language	Order No.
German, English, French, Spanish, Italian, Dutch	1088951

Service manual:

Language	Order No.
German	2355505
English	2355506

Additional languages on request or at: www.wagner-group.com**1.4 ABBREVIATIONS**

Order No.	Order number
ET	Spare part
K	Marking in the spare parts lists
Pos	Position
Stk	Number of pieces
SW	Wrench size

LV	Low-viscosity (LV) products
HV	High-viscosity (HV) products
LA	Low air
GM	Manual gun
AC	AirCoat
--	--

1.5 TERMINOLOGY FOR THE PURPOSE OF THIS MANUAL

Cleaning	
Cleaning	Manual cleaning of devices and device parts with cleaning agent
Flushing	Internal flushing with compressed air of parts carrying paint
Product pressure generator	Pump or pressure tank
Staff qualifications	
Trained person	Is instructed in the tasks assigned to him/her, the potential risks associated with improper behavior as well as the necessary protective devices and measures.
Electrically trained person	Is instructed by an electrician about the tasks assigned to him/her, the potential risks associated with improper behavior as well as the necessary protective devices and measures.
Electrician	Can assess the work assigned to him/her and detect possible hazards based on his/her technical training, knowledge and experience in relevant provisions.
Skilled person	A person, who, based on his/her technical training, experience and recent vocational experience, has sufficient technical knowledge in the areas of explosion protection, protection from pressure hazards and electric hazards (if applicable) and is familiar with the relevant and generally accepted rules of technology so that he/she can inspect and assess the status of devices and coating systems based on workplace safety.

2 CORRECT USE

2.1 DEVICE TYPE

Airless manual gun for manually coating work pieces.

2.2 TYPE OF USE

The spray gun is intended for atomizing liquid coating products under pressure (airless process).

WAGNER explicitly prohibits any other use!

The device may only be operated under the following conditions:

- Use the device only to work with the products recommended by WAGNER.
 - Only operate the device as a whole.
 - Do not deactivate safety fixtures.
 - Use only WAGNER original spare parts and accessories.
 - The operating personnel must be trained on the basis of this operating manual.
- Follow the instructions in the operating manual.

2.3 FOR USE IN POTENTIALLY EXPLOSIVE AREAS

The device is suitable for use in potentially explosive areas as defined by UK statutory requirement SI 2016/1107, (see Explosion protection marking Chapter [3.1](#)).



2.4 PROCESSIBLE WORKING MATERIALS

Top-coat lacquers, primer paints, corrosion protection, textured lacquers, lyes, staining solvents, clear lacquers, separating agents, etc. with a solvent or water base. If you want to spray working materials other than the aforementioned, please contact a WAGNER representative.

Note:

Contact your local WAGNER dealer and the lacquer manufacturer if you encounter application problems.

2.5 MISUSE

Misuse can lead to physical injury and/or property damage!

Special attention must be paid that:

- No dry coating products, e.g. powder are processed;
- Do not process food, medicine or cosmetics.

3 IDENTIFICATION

3.1 EXPLOSION PROTECTION IDENTIFICATION

As defined by UK statutory requirement SI 2016/1107 (ATEX), the device is suitable for use in potentially explosive areas.

Device type: Airless manual gun
 Manufacturer: Wagner International AG
 CH-9450 Altstätten, Switzerland

 II 2 G T6 X

UKCA	UKCA-mark (UK Conformity Assessed)
Ex	Symbol for explosion protection
II	Device class II
2	Category 2 (Zone 1)
G	Ex-atmosphere gas
T6	Temperature class: maximum surface temperature < 85 °C; 185 °F
X	Special notes (see Chapter 3.2)

**UK
CA**



3.2 IDENTIFICATION "X"

Ignition temperature of the coating product

→ Ensure that the ignition temperature of the coating product is above the maximum surface temperature (85 °C; 185 °F).

Ambient temperature

→ Permissible ambient temperature: +5 °C to +40 °C; +41 °F to +104 °F.

Cleaning

If there are deposits on the surfaces, the device may form electrostatic charges. Flames or sparks can form during discharge.

→ Remove deposits from the surfaces to maintain conductivity.

3.3 USE IN AREAS SUBJECT TO EXPLOSION HAZARDS

Safe handling of WAGNER spray devices

Mechanical sparks can form if the device comes into contact with metal.

In an explosive atmosphere:

- Do not knock or push the device or components and tools against steel or rusty iron.
- Do not drop the device or components and tools.



National regulations

→ Ensure that the national explosion prevention rules and regulations are observed when setting up the device.

3.4 EXAMPLE TYPE PLATE: PROTEC GM 1-530

Pos	Designation
1	Wagner International AG
2	Serial number
3	Production date (month/year)
4	Spray gun designation
5	Maximum product pressure
6	Maximum product temperature
7*	Keep clear of nozzle
8*	Maximum product pressure
9*	Injection hazard
10	Warning
11	Skin injection hazard/Read instruction manual
12	Fire and explosion hazard/read operating manual
13	"Warning – Hot surface!"

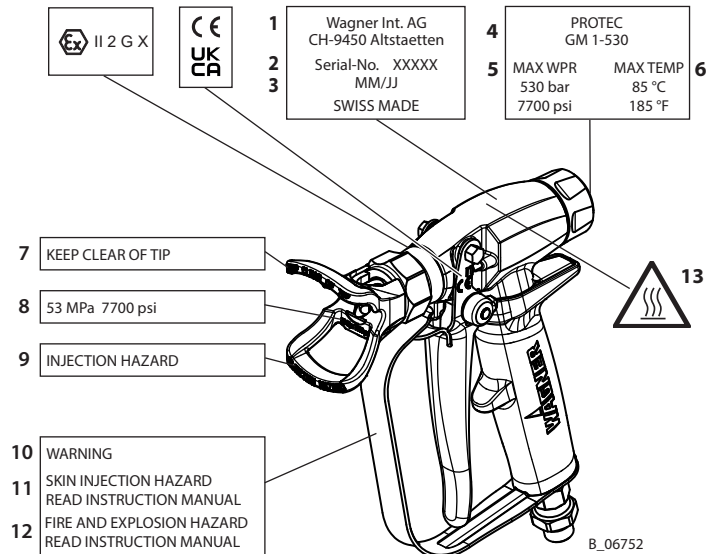

* For nozzle holder PT-HD GM1

4 BASIC SAFETY INSTRUCTIONS**4.1 SAFETY INSTRUCTIONS FOR THE OPERATOR**

- Keep this operating manual at hand near the device at all times.
- Always follow local regulations concerning occupational safety and accident prevention.

**4.1.1 ELECTRICAL DEVICES AND EQUIPMENT****Electric shock hazard!**

Danger to life from electric shock

- Prepare device in accordance with the local safety requirements with regard to the operating mode and ambient influences.
- May only be maintained by skilled electricians or under their supervision. With open housings, there is a danger from line voltage.
- Operate device in accordance with the safety regulations and electrotechnical regulations.
- Must be repaired immediately in the event of problems.
- Decommission if it poses a hazard or is damaged.
- Must be de-energized before work is commenced. Inform staff about planned work. Observe electrical safety regulations.
- Ground all devices to a common grounding point.
- Only operate the device with a properly installed socket with a protective ground wire connection.
- Keep liquids away from electrical devices.



4.1.2 A SAFE WORK ENVIRONMENT

Hazard due to dangerous fluids or steam!

Severe or fatal injuries due to explosion hazard or inhalation, swallowing or contact with the skin or eyes.

- Ensure that the floor in the working area is static dissipative in accordance with BS EN 61340-4-1:2004+A1:2015 (resistance must not exceed 100 MΩ).
- Paint mist extraction systems/ventilation systems must be fitted on site according to local regulations.
- Make sure that the ground connection and potential equalization of all system parts are reliable and continuous and can withstand the expected stress (e.g. mechanical stress, corrosion).
- Ensure that product / air hoses adapted to the working pressure are used.
- Ensure that personal protective equipment (see Chapter [4.2.1](#)) is available and is used.
- Ensure that all persons within the working area wear static dissipative shoes. Footwear must comply with BS EN ISO 20344:2011. The measured insulation resistance must not exceed 100 MΩ.
- Ensure that during spraying, persons wear electrically conductive gloves. The grounding takes place via the spray gun handle or the trigger.
- Protective clothing, including gloves, must comply with BS EN 1149-5:2018. The measured insulation resistance must not exceed 100 MΩ.
- Ensure that there are no ignition sources such as naked flames, sparks, glowing wires, or hot surfaces in the vicinity. No smoking.
- Ensure that the pipe joints, hoses, equipment parts and connections are permanently, technically leak-proof:
 - Periodic preventative maintenance and service (replacing hoses, checking tightness strength of the connections etc.).
 - Regular monitoring of leaks and defects via visual inspection and odor testing, e.g., daily before commissioning, at the end of work or weekly.
- In the event of defects, immediately bring the device or system to a stop and arrange to have repairs carried out immediately.



4.1.3 PERSONNEL QUALIFICATIONS

Hazard due to incorrect use of device!

Risk of death due to untrained personnel.

- Ensure that the operating personnel has been instructed by the operator in accordance with the operating manual and the operating instructions. The device must only be operated, maintained and repaired by trained personnel. Refer to the operating instructions for information about the required personnel qualifications.

4.2 SAFETY INSTRUCTIONS FOR STAFF

- Always follow the information in this manual, particularly the safety instructions and the warning instructions.
- Always follow local regulations concerning occupational safety and accident prevention.



4.2.1 USE PERSONAL SAFETY EQUIPMENT**Hazard due to dangerous fluids or steam!**

Serious or fatal injuries due to inhalation, swallowing or contact with the skin or eyes.

- When preparing or working with paint and when cleaning the device, follow the working instructions of the manufacturer of the lacquers, solvents, and cleaning agents being used.
- Take the specified protective measures. In particular wear safety goggles, protective clothing and gloves, as well as hand protection cream if necessary.
- Use a mask or breathing apparatus if necessary.
- For sufficient health and environmental safety: Operate the device in a spray booth or on a spraying wall with the ventilation (extraction) switched on.
- Wear suitable protective clothing when working with hot products.

**4.2.2 SAFE HANDLING OF WAGNER SPRAY DEVICES****Hazard due to injection of lacquer or flushing agent into the skin!**

The spray jet is under pressure and can cause dangerous injuries. Avoid injection of paint or flushing agents:

- Never point the spray gun at people.
- Never reach into the spray jet.
- Before any work on the device, in the event of work interruptions and malfunctions:
 - Relieve the pressure from the spray gun and device.
 - Secure the spray gun against actuation.
 - Switch off the energy/compressed air supply.
 - Disconnect the control unit from the mains.
 - In the event of functional faults, remedy the fault as described in the "Troubleshooting" chapter.
- If needed, the liquid ejection devices must be checked by experts (e.g., WAGNER service technician) at least every 12 months for their work-safe condition in accordance with DGUV regulation 100-500 Chapter 2.29 and Chapter 2.36.
 - For shut down devices, the examination can be suspended until the next start-up.
- Carry out the work steps as described in the "Pressure relief" chapter:
 - If pressure relief is required.
 - If the spraying work is interrupted or stopped.
 - before the device is cleaned on the outside, checked or serviced,
 - Before the spray nozzle is installed or cleaned.

**In the event of skin injuries caused by lacquer or flushing agents:**

- Note the lacquer or flushing agent that you have been using.
- Consult a doctor immediately.

Danger due to recoil forces!

Actuating the trigger can cause strong recoil forces. Thereby the user can lose his balance and injure himself during falling.

Avoid risk of injury from recoil forces:

- Ensure that you have firm footing when operating the spray gun.



4.2.3 GROUND THE UNIT**Hazard due to electrostatic charge!**

Explosion hazard and damage to the device.

Friction, flowing liquids and air or electrostatic coating processes create charges. Flames or sparks can form during discharge.

Correct grounding of the entire spraying system prevents electrostatic charges.

- Ensure that all devices and tanks are grounded before each spraying process.
- Ground the work pieces to be coated.
- Ensure that all persons inside the working area are grounded, e.g., that they are wearing static dissipative shoes.
- Wear static dissipative gloves when spraying. The grounding takes place via the spray gun handle or the trigger.
- The spray substance supply (spray substance tank, pump, etc.) must be grounded.

**4.2.4 PRODUCT HOSES****Hazard due to bursting of product hose!**

The product hose is under pressure and may cause dangerous injuries.

- Ensure that the hose material is chemically resistant to the sprayed products and the flushing agents used.
- Ensure that the product hose and the fittings are suitable for the pressure generated.
- Ensure that the following information can be seen on the high-pressure hose:
 - Manufacturer
 - Permissible operating pressure
 - Date of manufacture
- Make sure that the hoses are laid only in suitable places. Hoses should not be laid in the following places under any circumstances:
 - in high-traffic areas,
 - at sharp edges,
 - on moving parts or
 - on hot surfaces.
- Ensure that the hoses are never run over by vehicles (e.g., fork lifts), or that the hoses are never put under pressure from the outside in any other way.
- Ensure that the hoses are never kinked. Observe maximum bending radii.
- Ensure that no work is ever performed with a damaged hose.
- Make sure that the hoses are never used to pull or move the equipment.
- The electrical resistance of the product hose, measured at both valves, must be less than 1 MΩ.
- Suction hoses may not be subjected to pressure.



4.2.5 CLEANING AND FLUSHING

Hazard due to cleaning and flushing

Explosion hazard and damage to the device.

- Preference should be given to non-flammable cleaning and flushing agents.
- When carrying out cleaning work with flammable cleaning agents, make sure that all equipment and resources (e.g., collection tank, funnel, transport cart) are conductive or static dissipative and grounded.
- Observe the specifications of the lacquer manufacturer.
- Ensure that the flash point of the cleaning agent is at least 15 K above the ambient temperature or that cleaning is undertaken at a cleaning station with technical ventilation.
- Explosive gases are produced when aluminum comes into contact with halogenated hydrocarbons. To clean aluminum, do not use liquids containing halogenated hydrocarbons.
- Take measures for workplace safety (see Chapter [4.1.2](#)).
- When commissioning or emptying the device, please note that an explosive mixture may temporarily exist inside the lines and components of equipment:
 - depending on the coating product used,
 - depending on the flushing agent (solvent) used,
 an explosive mixture may temporarily exist inside the lines and items of equipment.
- Only electrically conductive tanks may be used for cleaning and flushing agents.
- The tanks must be grounded.



An explosive gas/air mixture forms in closed tanks.

- Never spray into a closed tank when using solvents for flushing.

External cleaning

When cleaning the exterior of the device or its parts, also observe the following:

- Relieve the pressure from the device.
- De-energize the device electrically.
- Disconnect the pneumatic supply line.
- Use only moistened cloths and brushes. Never use abrasive agents or hard objects and never spray cleaning agents with a gun. Cleaning the device must not damage it in any way.
- Ensure that no electric component is cleaned with or immersed into solvent.

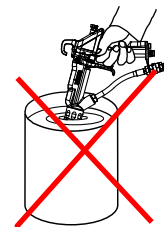

4.2.6 TOUCHING HOT SURFACES

Hazard due to hot surfaces because of hot coating products!

Risk of burn injuries

- Only touch hot surfaces if you are wearing protective gloves.
- When operating the device with a coating product with a temperature of > 43 °C; 109 °F:
 - Identify the device with a warning label "Warning – hot surface".

Order No.

9998910 Instruction label

9998911 Protection label

Note: Order the two stickers together.



4.2.7 MAINTENANCE AND REPAIR

Hazard due to improper maintenance and repair!

Danger to life and equipment damage.

- Only a WAGNER service center or a suitably trained person may carry out repairs and replace parts.
- Do not change or modify the device; if change is necessary, contact WAGNER.
- Only repair and replace parts that are listed in the [12](#) "Spare parts" chapter and [13](#) that are assigned to the unit.
- Do not use any defective components.
- Exclusively use accessories listed in Chapter [12](#) and that are assigned to the unit.
- Before all work on the device and in the event of work interruptions:
 - Relieve the pressure from the spray gun and device.
 - Secure the spray gun against actuation.
 - Switch off the energy and compressed air supply.
- Observe the operating and service manual for all work.

4.2.8 PROTECTIVE AND MONITORING EQUIPMENT

Hazard due to removal of protective and monitoring equipment!

Danger to life and equipment damage.

- Protective and monitoring equipment must not be removed, modified or rendered unusable.
- Regularly check for perfect functioning.
- If defects are detected on protective and monitoring equipment, the system must not be operated until these defects are remedied.

5 DESCRIPTION

5.1 COMPONENTS

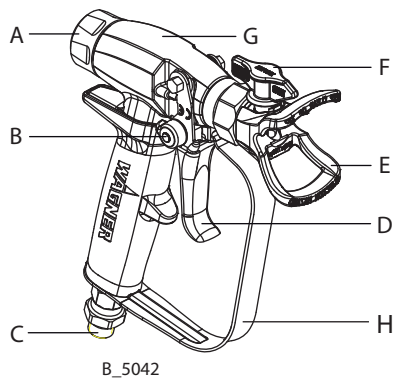

B_5042

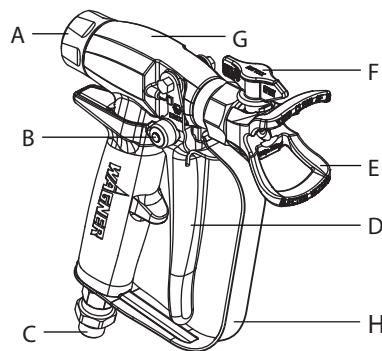

Pos	Designation
A	Preload nut
B	Trigger locking device
C	Product connection with swivel joint
D	Trigger

Pos	Designation
E	Nozzle holder
f	Reversible nozzle (not included in scope of delivery)
G	Gun housing
H	Guard bracket

5.2 MODE OF OPERATION

A high-pressure pump sucks in the coating product and conveys it under pressure to the nozzle in the spray gun. The coating product atomizes as it is pressed through the nozzle at high-pressure. The product valve opens if the trigger (D) is operated with the locking device (B) released. The spray profile changes depending on the nozzle selection.

5.3 SAFETY FIXTURES

Secure the spray gun with the locking device (B).

The guard bracket (H) protects the trigger (D) from being unintentionally activated.

The nozzle holder has an anti-contact guard (E).

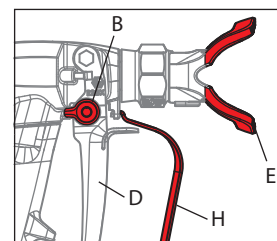

B_06750

5.4 INCLUDED ITEMS

This Airless manual gun is available in two different variants (350 bar, 530 bar). The choice of nozzle depends on the application, therefore these components are not included in the scope of delivery. A selection guide for gun accessories can be found in Chapter .

Stk	Order No.	Designation	Field of application
1	2349286	PROTEC GM 1-350	35 MPa; 350 bar; 5075 psi, NPSM1/4" product connection
1	2349287	PROTEC GM 1-530	53 MPa; 530 bar; 7700 psi, NPSM1/4" product connection

The standard equipment for spray guns includes:

Stk	Order No.	Designation
1	2355332	Declaration of Conformity
1	2348756	Operating manual, German
1	see Chapter 1.3	Operating manual in local language

For special versions the delivery note applies.

5.5 DATA**5.5.1 MATERIALS OF PAINT WETTED PARTS**

Metals			Plastics	
Carbide	Stainless steel 1.4305	Aluminum	POM	UHMW-PE
Stainless steel 1.4301	Stainless steel 1.4104		PTFE	

5.5.2 TECHNICAL DATA

Description	Units	Airless manual gun	
		GM 1 - 350	GM 1 - 530
Maximum product pressure	MPa; bar; psi	35; 350; 5075	53; 530; 7700
Product connection	inch	NPSM 1/4"	
Filter *	Mesh	30, 50, 100, 150, 200	
pH range of the product	pH	3.5 – 9.0	
Maximum product temperature	°C; °F	85; 185	
Maximum surface temperature	°C; °F	85; 185	
Maximum ambient temperature	Operation	+5...+40; +41...+104	
	Suspension	-20...+60; -4...+140	
Relative humidity (operation, storage)	%	10–95	
Sound level at 12 MPa; 120 bar; 1740 psi product pressure**	dB(A)	75	
Weight	g; oz	511; 18.0	581; 20.5
Dimensions	mm; inch	Length: 163; 6.42 Height: 195; 7.68 Width: 39; 1.54	

* For filter sizes, see Chapter [13.2](#)

** A-rated sound pressure level measured at 0.5 m distance, Lpa 0.5 m, according to BS EN 14462:2015.

6 ASSEMBLY AND COMMISSIONING

6.1 TRAINING OF ASSEMBLY/COMMISSIONING STAFF

- The assembly and commissioning staff must have the technical skills to safely commission the device.
- When assembling, commissioning and carrying out all work, read and follow the operating manuals and safety regulations for the additionally required system components.

A skilled person must check to ensure that the device is in a reliable state after it is installed and commissioned.

6.2 STORAGE CONDITIONS

Until the point of assembly, the device must be stored in a dry location, free from vibrations and with a minimum of dust. The device must be stored in closed rooms. For ambient temperature and air humidity, see Chapter [5.5.2](#).

6.3 TYPICAL AIRLESS SPRAYING SYSTEM

The Airless manual gun PROTEC GM 1-350/530 must be combined with various components to make up a spraying system. The system shown in the figure is only one example of an Airless spraying system. Your WAGNER distributor would be happy to assist you in creating a spraying system solution that meets your individual needs.

You must familiarize yourself with the operating manuals and the safety regulations for all additional system components required before starting with commissioning.

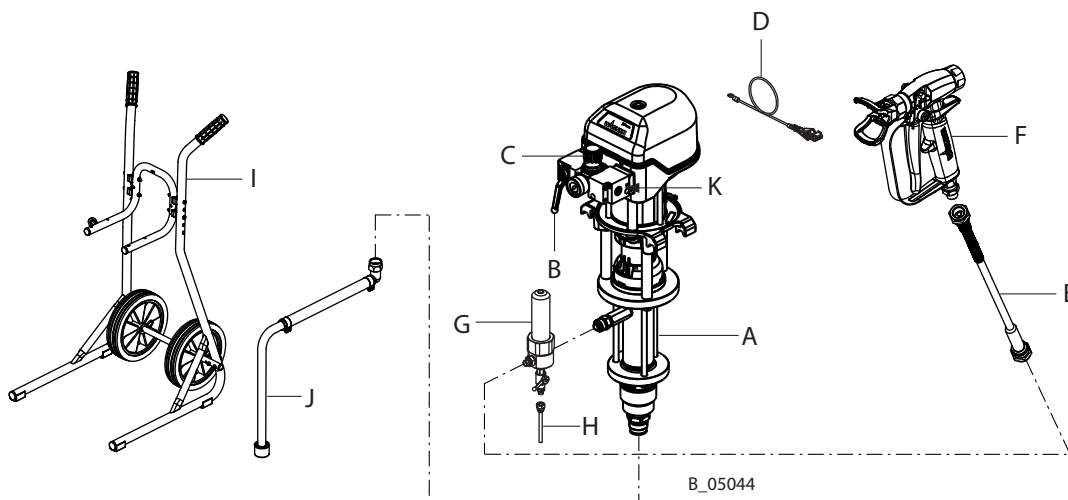

Pos	Designation
A	Product pump
B	Pressure air shut-off valve
C	Pressure regulator
D	Grounding cable
E	High-pressure product hose, electrically conductive

Pos	Designation
f	Airless manual gun
G	High-pressure filter/fluid pressure release
H	Return line
I	Pump mounting trolley
J	Suction system
K	Compressed air main

6.3.1 VENTILATION OF THE SPRAY BOOTH

- Operate the device in a spray booth approved for the working materials.
-or-
- Operate the device on an appropriate spraying wall with the ventilation (extraction) switched on.
- Observe national and local regulations for the exhaust air speed.

6.4 GROUNDING

A conductive connection (potential equalization cable) must be established between original bundles and the equipment.

WARNING

Discharge of electrostatically charged components in atmospheres containing solvents!

Explosion hazard from electrostatic sparks or flames.

- Ground all device components.
- Ground the work pieces to be coated.



Grounding check

- **Daily:** Before starting work, carry out a visual inspection to ensure that the system is grounded.

6.5 LACQUER PREPARATIONS

The viscosity of the lacquer is of great importance. The best spraying results are obtained with values between 80 and 260 millipascals x sec (mPa·s).

Please also read the technical data sheet of the lacquer for optimal processing, viscosity adjustment and intermixing of the product.

6.6 COMMISSIONING

6.6.1 PREPARATION

NOTICE

Impurities in the spraying system!

Spray gun blockage, products harden in the spraying system.

→ Flush the spray gun and paint supply with a suitable flushing agent.

6.6.2 PROCEED

1. Secure the spray gun.
2. For spray guns with filters →, insert a suitable filter (filter insert, see Chapter [13.2](#)).
3. Connect the product hose to the spray gun and product supply system.
4. - Insert nozzle holder PT-HD GM1: Set of seals (saddle and seal) into the nozzle holder. Push in nozzle. Screw the entire nozzle holder onto the spray gun. Tighten nozzle holder using a size 30 wrench (SW 30).
- Nozzle holder WAGNER Tip 7/8 UNF: Insert seal in nozzle holder, screw nozzle holder onto spray gun and push in nozzle according to supplement WAGNER Tip (For Order No., see Chapter [1.3](#)).
- Anti-contact guard 7/8 UNF: Insert nozzle in anti-contact guard. Insert seal. Screw the entire nozzle holder onto the spray gun. Tighten nozzle holder using a size 27 wrench (SW 27).
5. Visually check the permissible pressures for all the system components.
6. Make sure that the device and all other conductive parts within the work area are grounded.
7. To perform a leak test on the entire installation, the pressure is slowly increased using a suitable medium, step by step, until the maximum pressure indicated on the type plate is reached.

Note:

- Set the operating pressure to 100 bar; 10 MPa; 1450 psi.
 - Pull the trigger and check whether the gun closes cleanly upon release.
8. Relieve the pressure of the spray gun and product pressure generator and secure the spray gun.

6.6.3 VERIFYING A SAFE OPERATIONAL CONDITION

A skilled person must check to ensure that the device is in a reliable state after it is installed and commissioned.

This includes:

- Carry out a safety checks in accordance with Chapter [8.2.3](#).



7 OPERATION

7.1 TRAINING THE OPERATING STAFF

- The operating staff must be qualified to operate the entire system.
- The operating staff must be familiar with the potential risks associated with improper behavior as well as the necessary protective devices and measures.
- Before work commences, the operating staff must receive appropriate system training.

7.2 WORK

Ensure that:

- The regular safety checks are carried out in accordance with Chapter [8.2.3](#),
- Commissioning is carried out in accordance with section [6.6](#).

7.2.1 STARTING TO SPRAY WITH THE AIRLESS

1. Start up with product supply set to approx. 10 MPa; 100 bar; 1450 psi operating pressure.
2. Spray (release locking device and pull trigger) and at the same time observe how the product is atomizing.
3. Set the fluid pressure on the product pump to a point where good product atomization is achieved.

Note:

- Adjust the nozzle, product pressure and product temperature until you find the optimum setting.
- The amount of product can be adjusted by changing the product pressure and temperature or by inserting another nozzle (see Chapter [7.2.3](#) and Chapter [12](#)).

7.2.2 PRESSURE RELIEF/WORK INTERRUPTION

The pressure must always be relieved:

- when the spraying tasks are finished,
- before carrying out maintenance work on the spraying system,
- before carrying out cleaning tasks on the spraying system,
- before moving the spraying system to another location,
- if something must be checked on the spraying system,
- if the nozzle or the filter is removed from the spray gun.

The components for pressure relief on a CE-compliant spray system include:

- Air cock with pressure relief hole mounted between compressed air source and pneumatic pump.
- Product pressure relief valve mounted between pump and spray gun.

Pressure relief procedure

1. Close and secure the spray gun.
2. Relieve the air and product pressure in the product pressure generator in accordance with the respective operating manual.
3. Point the spray gun into the grounded metal bucket for return product.
4. Release and open spray gun to relieve the pressure. Avoid splashback.
5. When no further overpressure is detected, close and secure the spray gun.

In the case of a clogged nozzle, proceed in accordance with Chapter [7.2.5](#).

7.2.3 CHANGING THE AIRLESS NOZZLE

In the case of a clogged nozzle, proceed in accordance with Chapter [7.2.5](#).

! NOTICE**Defective Airless nozzle!**

Insufficient paint application quality.

- Do not use sharp-edged objects on the carbide on the Airless nozzle.

Nozzle holder PT-HD GM1

Nozzles can be removed and replaced without having to take apart the spray gun.

1. Relieve the pressure on the spray gun and product pressure generator in accordance with Chapter [7.2.2](#).
2. Secure the spray gun with the locking device.
3. Point the spray gun at the ground. Loosen the nozzle holder.
4. Turn the reversing nozzle 90° to the right and remove it from the nozzle holder.
5. Place a new nozzle in the nozzle holder (turned 90° to the right).
6. Align the nozzle holder and tighten it using a size 30 wrench (SW 30).
7. Turn the reversing nozzle into the spray position.

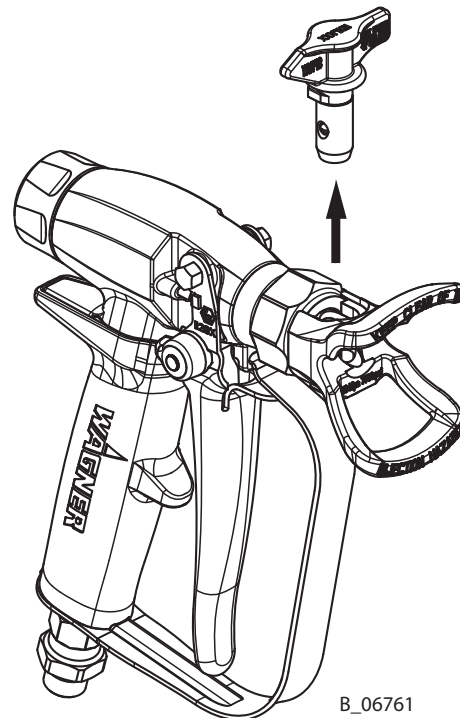

B_06761

Nozzle holder WAGNER Tip 7/8 UNF

Nozzles can be removed and replaced without having to take apart the Airless spray gun.

1. Relieve the pressure on the spray gun and product pressure generator in accordance with Chapter [7.2.2](#).
2. Secure the spray gun with the locking device.
3. Point the spray gun at the ground. Remove the nozzle from the opening on the nozzle holder in accordance with supplement WAGNER Tip (For Order No., see Chapter [1.3](#)).
4. Place new nozzle in the opening on the nozzle holder in accordance with supplement WAGNER Tip (For Order No., see Chapter [1.3](#)).

Anti-contact guard 7/8 UNF

1. Relieve the pressure on the spray gun and product pressure generator in accordance with Chapter [7.2.2](#).
2. Secure the spray gun with the locking device.
3. Point the spray gun at the ground. Unscrew anti-contact guard Remove seal. Remove nozzle.
4. Insert new nozzle in the anti-contact guard. Insert seal. Screw the entire anti-contact guard onto the spray gun. Align nozzle and tighten the anti-contact guard with a size 27 wrench (SW 27).

7.2.4 CLEANING THE AIRLESS NOZZLE

For disassembly and assembly of Airless nozzles, see Chapter [7.2.3](#).

The Airless nozzle can be placed into a cleaning solution recommended by the paint manufacturer.

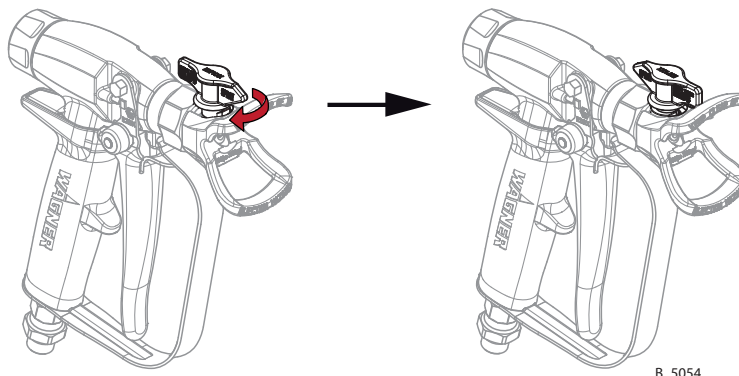
7.2.5 CELIMINATE NOZZLE CLOGGING**Nozzle holder PT-HD GM1**

B_5054

1. Relieve the pressure on the spray gun and product pressure generator in accordance with Chapter [7.2.2](#).
2. Secure the spray gun with the locking device.
3. **⚠ CAUTION**

Product emission from product inclusions between nozzle and valve seat!

Injury due to contact with dangerous liquids.

→ When turning or removing the reversing nozzle, always keep the spray gun pointed at the ground.

Rotate the reversing nozzle 180° so that its tip is pointing opposite the direction of spray.

4. Briefly trigger the spray gun so that the pressure eliminates the clog.
→ Only activate the trigger briefly if the nozzle is installed in the reversed direction.

Nozzle holder WAGNER Tip 7/8 UNF

1. Relieve the pressure on the spray gun and product pressure generator in accordance with Chapter [7.2.2](#).
2. Secure the spray gun with the locking device.
3. **⚠ CAUTION**

Product emission from product inclusions between nozzle and valve seat!

Injury due to contact with dangerous liquids.

→ When loosening the nozzle, always keep the spray gun pointed at the ground.

Loosen nozzle by $\frac{3}{4}$ rotation.

4. Turn the nozzle 180° in accordance with supplement WAGNER Tip (For Order No., see Chapter [1.3](#)).
5. Briefly trigger the spray gun so that the pressure eliminates the clog.
→ Only activate the trigger briefly if the nozzle is installed in the reversed direction.

Anti-contact guard 7/8 UNF1. **⚠ CAUTION****Product emission from product inclusions between nozzle and valve seat!**

Injury due to contact with dangerous liquids.

→ When loosening the anti-contact guard, always keep the spray gun pointed at the ground.

Clean the nozzle in accordance with Chapter [7.2.4](#).**7.2.6 HORIZONTAL/VERTICAL SPRAYING****Nozzle holder PT-HD GM1**

1. Secure the spray gun with the locking device.
2. Rotate the reversing nozzle 90° to the right, so that the nozzle is pointing transverse to the direction of spray.
3. Turn the nozzle holder to the desired position.

Attention: always turn the nozzle holder clockwise (see illustration) so that the threaded connection cannot become loose. After turning, check whether the nozzle holder is tight. If not, tighten.

4. Turn the reversing nozzle back into the spray position.

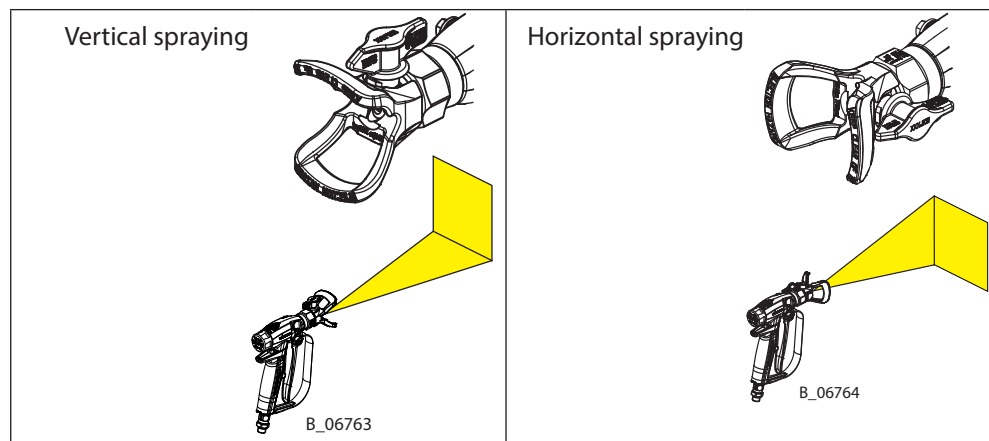
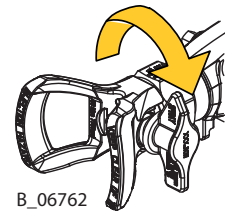
**Nozzle holder WAGNER Tip 7/8 UNF**

1. Relieve the pressure on the spray gun and product pressure generator in accordance with Chapter [7.2.2](#).
2. Secure the spray gun with the locking device.
3. Loosen the anti-contact guard by a few rotations.
4. Setting the nozzle lever:
 - Nozzle horizontal – spray jet vertical
 - Nozzle vertical – spray jet horizontal
5. Tightly fasten union nut.

See also WAGNER Tip (For Order No., see Chapter [1.3](#)).**Anti-contact guard 7/8 UNF**

1. Relieve the pressure on the spray gun and product pressure generator in accordance with Chapter [7.2.2](#).
2. Secure the spray gun with the locking device.
3. Point the spray gun at the ground. Loosen anti-contact guard.
4. Align nozzle and tighten the anti-contact guard with a size 27 wrench (SW 27).

8 CLEANING AND MAINTENANCE

8.1 CLEANING

8.1.1 CLEANING STAFF

Cleaning work should be undertaken regularly and carefully by qualified and trained staff. They should be informed of specific hazards during their training.

The following hazards may arise during cleaning work:

- Health hazard from inhaling solvent vapors
- Use of unsuitable cleaning tools and aids

8.1.2 FLUSHING AND CLEANING THE SPRAY GUN

The spray gun and the device must be cleaned and flushed daily. The cleaning and flushing agents used must be compatible with the working material.

Note:

Methylene chloride is not recommended as an agent for flushing or cleaning the spray gun or other system components.

Pos	Description
1	Product inlet
2	Locking device in secured position

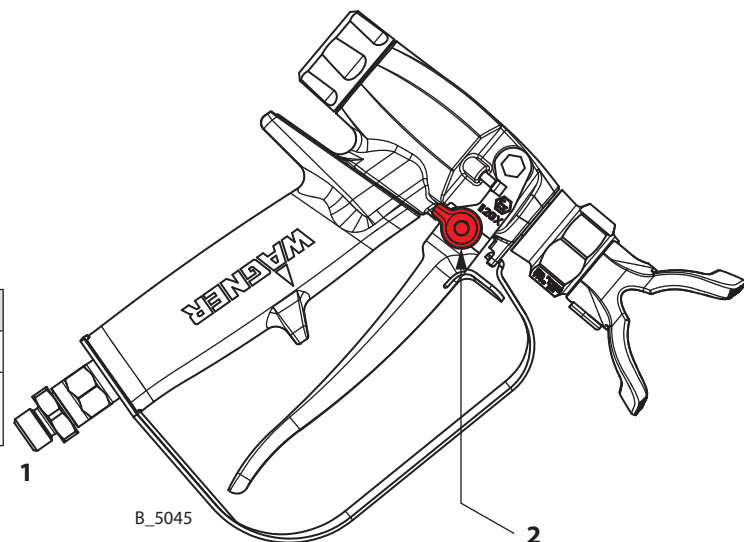

1. Relieve the pressure on the spray gun and product pressure generator in accordance with Chapter [7.2.2](#).
2. Secure the spray gun with the locking device.
3. Connect the solvent supply.
4. Disassemble the Airless nozzle and clean it separately (see Chapter [7.2.3](#) and [7.2.4](#)).
5. Raise the pressure of the rinsing agent supply to a maximum of 4 MPa; 40 bar; 580 psi, unlock the spray gun and thoroughly rinse it.
6. Relieve the pressure on the spray gun and product pressure generator.
7. Secure the spray gun with the locking device.
8. Clean the gun body with a cleaning agent recommended by the lacquer manufacturer. Clean the trigger locking device area.
9. Dry with a cloth or a blow gun.

8.2 MAINTENANCE

8.2.1 MAINTENANCE STAFF

Maintenance work should be undertaken regularly and carefully by qualified and trained staff. They should be informed of specific hazards during their training.

The following hazards may arise during maintenance work:

- Health hazard from inhaling solvent vapors
- Use of unsuitable tools and aids

An authorized person must ensure that the device is checked for being in a reliable state after maintenance work is completed.

8.2.2 MAINTENANCE INSTRUCTIONS

DANGER

Incorrect maintenance/repair!

Danger to life and equipment damage.

- Only a WAGNER service center or a suitably trained person may carry out repairs and replace parts.
- Only repair and replace parts that are listed in the "Spare parts" chapter and that are assigned to the unit.
- Before all work on the device and in the event of work interruptions:
 - Relieve the pressure from the spray gun and device.
 - Secure the spray gun against actuation.
 - Switch off the energy and compressed air supply.
- Observe the operating and service manual for all work.



Prior to maintenance

- Flush and clean the system. → Section [8.1.2](#)

After maintenance

- Carry out a safety checks in accordance with Chapter [8.2.3](#).
- Put the system into operation and check for leaks as described in section [6.6](#).
- Have the system checked for safe condition by an authorized person.

8.2.3 SAFETY CHECKS AND MAINTENANCE INTERVALS**Every day**

- Check grounding: see Chapter [6.4](#)
- Check hoses, tubes and couplings: see Chapter [8.2.4](#)
- Flush and clean the spray gun as described in Chapter [8.1.2](#).

Weekly

- Check spray guns for damage.
- Check the function of the safety fixtures (see Chapter [5.3](#)):
 - Anti-contact guard on nozzle holder.
 - Guard bracket
 - Trigger locking device must engage and block the trigger.

Yearly or as required

- In accordance with DGUV regulation 100-500 Chapter 2.29 and 2.36:
 - The liquid ejection devices should be checked by an expert (e.g., WAGNER service technician) for their safe working conditions as required and at least every 12 months.
 - For shut down devices, the examination can be suspended until the next start-up.

8.2.4 PRODUCT HOSES, TUBES AND COUPLINGS

The service life of the complete hoses between product pressure generator and application device is reduced due to environmental influences even when handled correctly.

- Check hoses, pipes, and couplings every day and replace if necessary.
- Additionally, the operator must regularly check the complete hoses for wear and tear as well as for damage at intervals that he/she has set. Records of these checks must be kept.
- The complete hose is to be replaced as soon as one of the two following intervals has been exceeded:
 - 6 years from the date of the hose crimping (see fitting embossing).
 - 10 years from the date of the hose imprinting.

Fitting embossing	Meaning
xxx bar	Pressure
yymm	Crimping date (year/month)
XX	Internal code

Hose imprinting	Meaning
WAGNER	Name / Manufacturer
yymm	Date of manufacture (year/month)
xxx bar (xx MPa) e.g., 270 bar (27 MPa)	Pressure
XX	Internal code
DNxx (e.g., DN10)	Nominal diameter

8.2.5 REPLACING THE PRODUCT HOSE

1. Flush and clean the spray gun as described in Chapter [8.1.2](#).
2. Relieve the pressure on the spray gun and product pressure generator in accordance with Chapter [7.2.2](#).
3. Secure the spray gun with the locking device.

Product hose

4. Place the size B wrench on the lower wrench size across flats of the product connection and hold it in place.
5. Unscrew the product hose nut using the size A wrench.

Assembly

6. Fit product hose by hand and tighten with 2 wrenches.

Description	Wrench A	Wrench B
	Wrench size	Wrench size
PROTEC GM 1-350/530 with filter NPS1/4"	17 mm 0.67 inch	19 mm 0.75 inch

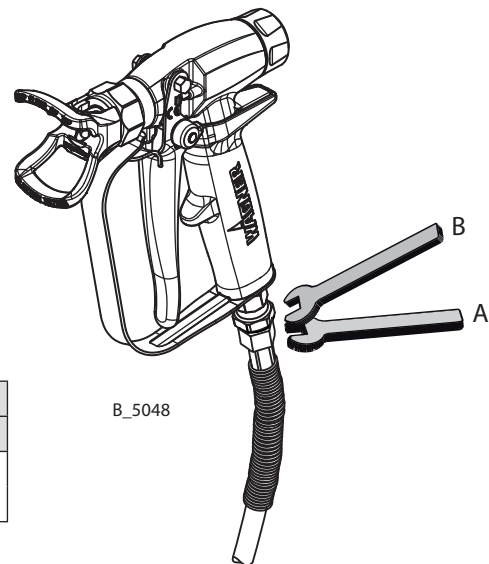
**8.2.6 REPLACING THE NOZZLE SEAL****Nozzle holder PT-HD GM1**

1. Flush and clean the spray gun as described in Chapter [8.1.2](#).
2. Ensure that the system has been relieved of pressure and that the spray gun is secured.
3. Remove reversing nozzle (A).
4. Unscrew nozzle holder (B).
5. Carefully release saddle (C) and nozzle sealing (D) using a screwdriver.
6. Insert a new nozzle seal (D) and saddle (C) into the nozzle holder noting the installation position (see illustration).
7. Screw the nozzle holder onto the spray gun and push the reversing nozzle (A) into the opening.
→ The tip of the reversing nozzle must point forward in the direction of spray.

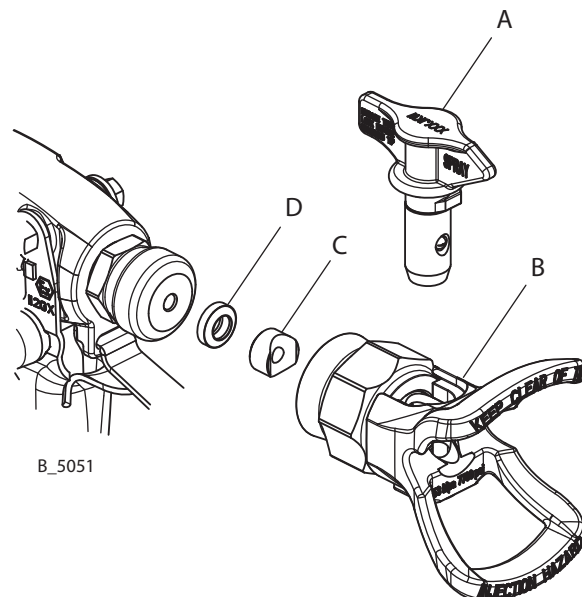
**Nozzle holder WAGNER Tip 7/8 UNF**

1. Flush and clean the spray gun as described in Chapter [8.1.2](#).
2. Ensure that the system has been relieved of pressure and that the spray gun is secured.
3. Replace the seal in accordance with supplement WAGNER Tip (For Order No., see Chapter [1.3](#)).

Anti-contact guard 7/8 UNF

1. Flush and clean the spray gun as described in Chapter [8.1.2](#).

2. Ensure that the system has been relieved of pressure and that the spray gun is secured.
3. Unscrew anti-contact guard Remove nozzle seal.
4. Insert new nozzle seal. Screw the entire anti-contact guard onto the spray gun. Tighten the anti-contact guard with a size 27 wrench (SW 27).

8.2.7 CHANGING OR CLEANING FILTER INSERT

1. Flush and clean the spray gun in accordance with Chapter [8.1.2](#).
2. Relieve the pressure on the spray gun and product pressure generator in accordance with Chapter [7.2.2](#).
3. Secure the spray gun with the locking device.
4. Use the guard bracket (B) with integrated hex tool to loosen and unscrew the filter housing (A).
5. Remove the filter insert (C) from the filter housing (A).
6. Thoroughly clean the filter housing and gun handle with cleaning agent.

Assembly

7. Insert a new filter insert (C) with opening downwards into the filter housing (A). Check the seal (F) to make sure it is in good condition and positioned correctly.
Note: if the seal (F) becomes damaged, it must also be replaced (order No. 364340).
8. Use the guard bracket to screw in and tighten the filter housing (A).

Note: If the filter insert (C) gets stuck in the filter socket (E), pull off the gun handle (D) and carefully remove the filter insert (C).

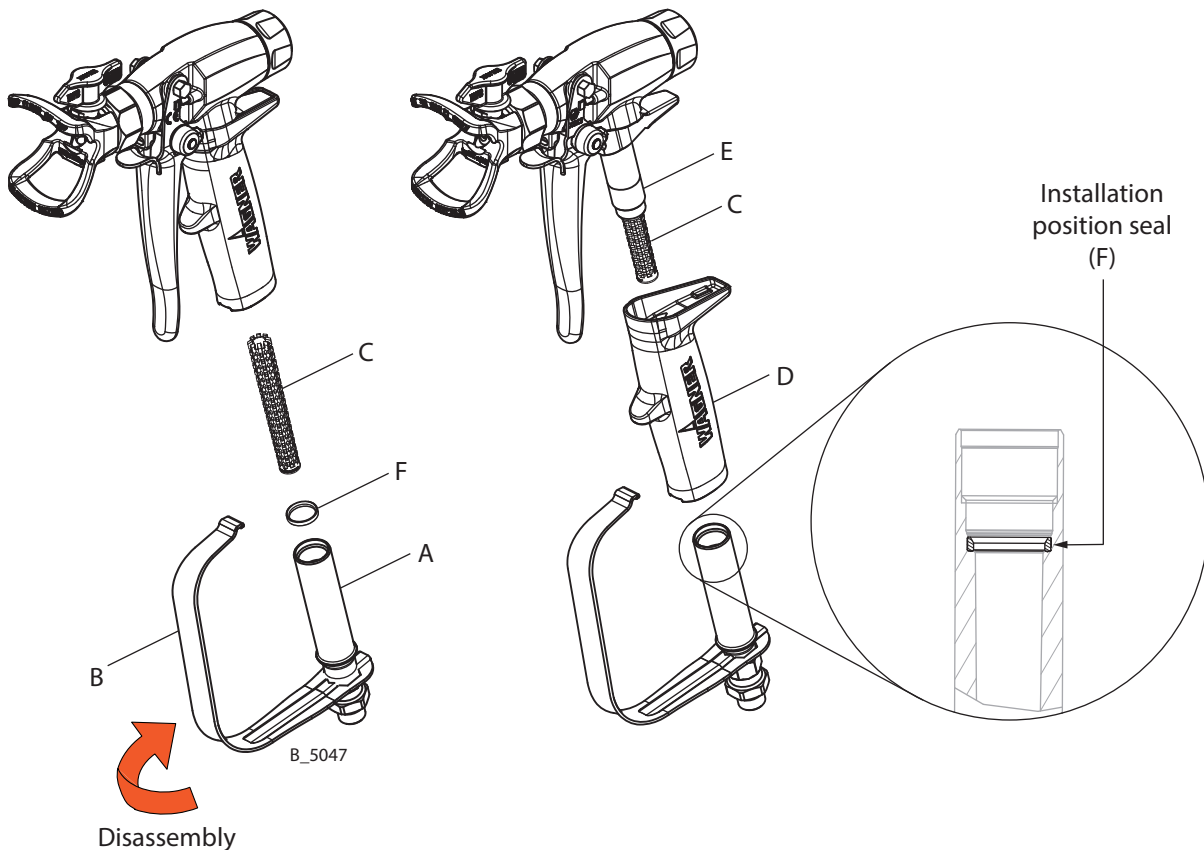

9 TROUBLESHOOTING

Functional fault	Cause	Remedy	See Chapter
Insufficient product output	Nozzle too small.	Select larger nozzle.	12
	Product pressure too low.	Increase product pressure.	
	Gun filter or high-pressure filter clogged at pump	Clean or replace filter.	8.2.7
	Nozzle is clogged.	Nozzle cleaning	7.2.4 / 7.2.5
	Filter/nozzle pairing does not match.	Change filter and/or nozzle.	7.2.3 and 8.2.7
	The valve rod path is too short.	Replace valve rod unit.	See service manual
Poor spray pattern	Nozzle worn.	Replace nozzle.	7.2.3
	Product pressure too low.	Increase the product pressure at pump.	
	The product viscosity is too high.	Dilute the spray product in accordance with the manufacturer's instructions.	
	The nozzle is partially clogged.	Nozzle cleaning	7.2.4 and 7.2.5
Product emission on nozzle holder	Seal of nozzle holder or anti-contact guard damaged.	Replace seal or set of seals.	8.2.6
Product emission from gun body	Packing in the valve rod unit leaky	Replace valve rod unit.	See service manual
Product emission from the nozzle (Gun will not shut off correctly)	Valve ball is damaged.	Replace valve rod unit.	See service manual
	Valve seat is damaged.	Replace intermediate piece.	

10 REPAIR WORK

10.1 REPAIR STAFF

Repair work should be undertaken carefully by qualified and trained personnel. They should be informed of specific hazards during their training. The repairs must be carried out in accordance with the corresponding service manual (For Order No., see Chapter [1.3](#)).

The following hazards may arise during repair work:

- Health hazard from inhaling solvent vapors
- Use of unsuitable tools and aids

A skilled person must check to ensure that the device is in a reliable state after it is repaired.

11 DISPOSAL

When the equipment must be scrapped, please differentiate the disposal of the waste materials.

The following materials have been used:

Stainless steel	Aluminum	Plastics	Carbide
-----------------	----------	----------	---------

Consumable products (lacquers, adhesives, flushing and cleaning agents) must be disposed of in accordance with all applicable legal requirements.



12 ACCESSORIES

→ Nozzle holder / anti-contact guard: see Chapter [13.2](#)

12.1 NOZZLE FOR NOZZLE HOLDER PT-HD GM1

Nozzle table **WAGNER Profi Tip HD**

Order No. In order to determine the order number of a nozzle, please select the number from the table and replace the three xxx.
1006xxx Example: This means nozzle 411 has order number: 1006411



Size	Spray angle							
	10°	20°	30°	40°	50°	60°	70°	80°
07 ***				407				
09 ***		209	309	409	509	609		
11	111	211	311	411	511	611		
13	113	213	313	413	513	613		813
15	115	215	315	415	515	615	715	815
17		217	317	417	517	617	717	
19		219	319	419	519	619	719	819
21		221		421	521	621		821
23		223		423	523	623	723	823
25		225		425	525	625		825
27		227		427	527	627		827
29						629		
31		231		431	531	631		
35		235		435	535	635		
43		243			543			
52					552			

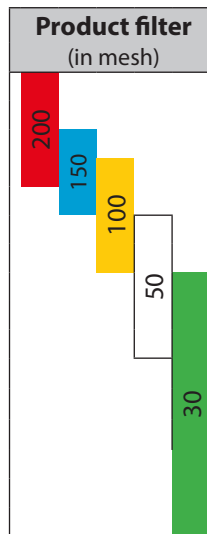

Drilled hole		Product flow *	
inch	mm	l/min	gal/min
0.007	0.18	0.21	0.055
0.009	0.23	0.23	0.061
0.011	0.28	0.34	0.090
0.013	0.33	0.50	0.132
0.015	0.38	0.68	0.180
0.017	0.43	0.88	0.232
0.019	0.48	1.09	0.288
0.021	0.53	1.31	0.346
0.023	0.58	1.63	0.431
0.025	0.64	1.92	0.507
0.027	0.69	2.25	0.594
0.029	0.75	2.58	0.682
0.031	0.79	2.95	0.779
0.035	0.89	3.80	1.004
0.043	1.10	5.00	1.321
0.052	1.30	6.14	1.622

51	104	152	203	254	305	356	406
(2.0)	(4.0)	(6.0)	(8.0)	(10.0)	(12.0)	(14.0)	(16.0)

Spray jet width in mm (inch) **

* Tested with water and 100 bar pressure.
 ** ** Spray jet width at approx. 30 cm distance from the sprayed object and 110 bar (11 MPa) of pressure with lacquer 56 DIN/4 seconds
 *** Possible deviations in the spray jet width

Nozzle table **PROTEC tip**

Order No. In order to determine the order number of a nozzle, please select the number from the table and replace the three xxx.
556xxx Example: This means nozzle 417 has order number: 556417



Size	Spray angle							
	10°	20°	30°	40°	50°	60°	70°	80°
13	113	213	313	413				
15	115	215	315	415	515			815
17	117	217	317	417	517	617		817
19	119	219	319	419	519	619		
21		221	321	421	521	621		
23		223	323	423	523			
25		225	325	425	525			
31					531			
33								
35					535			
51								
55								
61								
65								

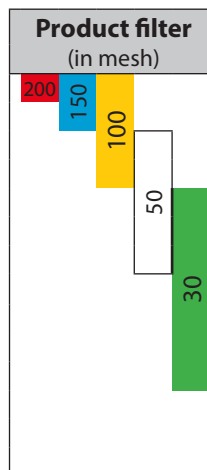

Drilled hole		Product flow *	
inch	mm	l/min	gal/min
0.013	0.33	0.50	0.15
0.015	0.38	0.70	0.19
0.017	0.43	0.85	0.22
0.019	0.48	1.00	0.26
0.021	0.53	1.20	0.32
0.023	0.58	1.40	0.37
0.025	0.64	1.60	0.42
0.031	0.79	2.25	0.60
0.033	0.84	2.50	0.66
0.035	0.89	2.80	0.74
0.051	1.30	5.20	1.38
0.055	1.40	6.00	1.59
0.061	1.55	7.50	1.98
0.065	1.65	9.00	2.38

51	104	152	203	254	305	356	406
(2.0)	(4.0)	(6.0)	(8.0)	(10.0)	(12.0)	(14.0)	(16.0)

Spray jet width in mm (inch) **

* Tested with water and 100 bar pressure.
 ** ** Spray jet width at approx. 30 cm distance from the sprayed object and 110 bar (11 MPa) of pressure with lacquer 56 DIN/4 seconds

OPERATING MANUAL



12.2 NOZZLE FOR NOZZLE HOLDER WAGNER TIP 7/8 UNF

Nozzle table WAGNER Tip

Order No.
1088xxx

In order to determine the order number of a nozzle, please select the number from the table and replace the three xxx.
Example: This means nozzle 411 has order number: 1088411



Size	Spray angle							
	10°	20°	30°	40°	50°	60°	70°	80°
07 ***				407				
09 ***		209	309	409	509	609		
11	111	211	311	411	511	611		
13	113	213	313	413	513	613		813
15	115	215	315	415	515	615	715	815
17		217	317	417	517	617	717	
19		219	319	419	519	619	719	819
21		221		421	521	621		821
23		223		423	523	623	723	823
25		225		425	525	625		825
27		227		427	527	627		827
29						629		
31		231		431	531	631		
35		235		435	535	635		
43		243			543			
52					552			

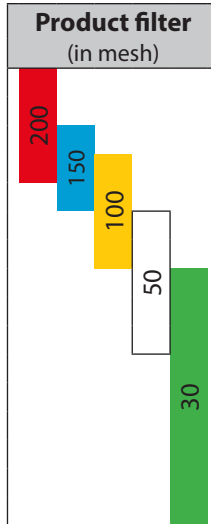

Drilled hole		Product flow *	
inch	mm	l/min	gal/min
0.007	0.18	0.21	0.055
0.009	0.23	0.23	0.061
0.011	0.28	0.34	0.090
0.013	0.33	0.50	0.132
0.015	0.38	0.68	0.180
0.017	0.43	0.88	0.232
0.019	0.48	1.09	0.288
0.021	0.53	1.31	0.346
0.023	0.58	1.63	0.431
0.025	0.64	1.92	0.507
0.027	0.69	2.25	0.594
0.029	0.75	2.58	0.682
0.031	0.79	2.95	0.779
0.035	0.89	3.80	1.004
0.043	1.10	5.00	1.321
0.052	1.30	6.14	1.622

51	104	152	203	254	305	356	406
(2.0)	(4.0)	(6.0)	(8.0)	(10.0)	(12.0)	(14.0)	(16.0)

Spray jet width in mm (inch) **

* Tested with water and 100 bar pressure.
** ** Spray jet width at approx. 30 cm distance from the sprayed object and 110 bar (11 MPa) of pressure with lacquer 56 DIN/4 seconds
*** Possible deviations in the spray jet width

12.3 NOZZLE FOR ANTI-CONTACT GUARD 7/8 UNF

Nozzle table Standard Tip

Order No.
90xxx

In order to determine the order number of a nozzle, please select the number from the table and replace the three xxx.
Example: This means nozzle 411 has order number: 90411



Size	Spray angle							
	10°	20°	30°	40°	50°	60°	70°	80°
07 ***				407	507			
09 ***		209	309	409	509	609		
11	111	211	311	411	511	611		
13	113	213	313	413	513	613		813
15	115	215	315	415	515	615	715	815
17		217	317	417	517	617	717	
19		219	319	419	519	619	719	819
21		221		421	521	621		821
23		223		423	523	623	723	823
25		225		425	525	625		825
27		227		427	527	627		827
29						629		
31		231		431	531	631		
35		235		435	535	635		
39								839
43		243			543			
52					552			

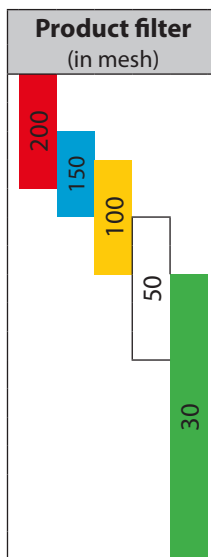

Drilled hole		Product flow *	
inch	mm	l/min	gal/min
0.007	0.18	0.21	0.055
0.009	0.23	0.23	0.061
0.011	0.28	0.34	0.090
0.013	0.33	0.50	0.132
0.015	0.38	0.68	0.180
0.017	0.43	0.88	0.232
0.019	0.48	1.09	0.288
0.021	0.53	1.31	0.346
0.023	0.58	1.63	0.431
0.025	0.64	1.92	0.507
0.027	0.69	2.25	0.594
0.029	0.75	2.58	0.682
0.031	0.79	2.95	0.779
0.035	0.89	3.80	1.004
0.039	0.99	4.32	1.141
0.043	1.10	5.00	1.321
0.052	1.30	6.14	1.622

51	104	152	203	254	305	356	406
(2.0)	(4.0)	(6.0)	(8.0)	(10.0)	(12.0)	(14.0)	(16.0)

Spray jet width in mm (inch) **

* Tested with water and 100 bar pressure.
** ** Spray jet width at approx. 30 cm distance from the sprayed object and 110 bar (11 MPa) of pressure with lacquer 56 DIN/4 seconds
*** Possible deviations in the spray jet width

13 SPARE PARTS

DANGER

Incorrect maintenance/repair!

Danger to life and equipment damage.

- Only a WAGNER service center or a suitably trained person may carry out repairs and replace parts.
- Only repair and replace parts that are listed in the "Spare parts" chapter and that are assigned to the unit.
- Before all work on the device and in the event of work interruptions:
 - Relieve the pressure from the spray gun and device.
 - Secure the spray gun against actuation.
 - Switch off the energy and compressed air supply.
- Observe the operating and service manual for all work.



13.1 HOW TO ORDER SPARE PARTS?

Always supply the following information to ensure delivery of the right spare part:

Order number, designation and quantity

The quantity need not be the same as the number given in the quantity column "**Stk**" on the list. This number merely indicates how many of the respective parts are used in each component.

The following information is also required to ensure smooth processing of your order:

- Address for the invoice
- Address for delivery
- Name of the person to be contacted in the event of any queries
- Type of delivery (normal mail, express delivery, air freight, courier, etc.)

Identification in spare parts lists.

Explanation of column "**K**" (labeling) in the following spare parts lists:

- ◆ Wearing parts
- ★ Included in service set

Note: These parts are not covered by warranty terms.

- Not part of standard equipment, available, however, as additional extra.



13.2 SPARE PARTS LIST PROTEC GM 1-350/530

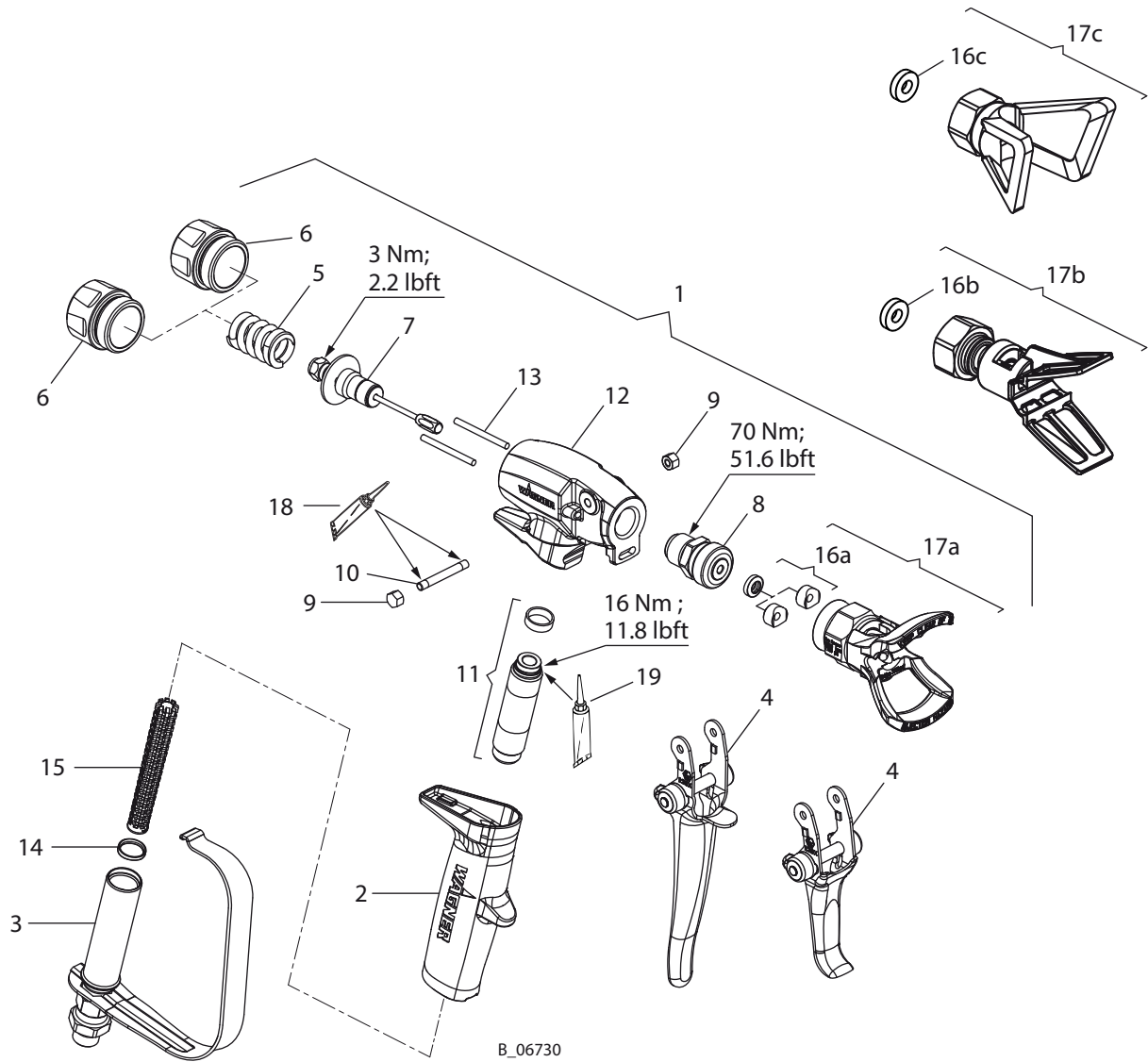

Pos	K	Stk	35 MPa Order No.	53 MPa Order No.	Designation
1		1	2349286	2349287	PROTEC GM 1
2		1	2346614		Handle
3		1	2353559		Filter housing with guard bracket
4		1	--	2353599	Trigger 4 finger
		1	2353600	--	Trigger 2 finger
5		1	347335		Pressure spring
6		1	--	2353606	Preload nut, 530 bar
		1	2353607	--	Preload nut, 350 bar
7	◆ ★	1	2353556		Valve rod unit
8	◆ ★	1	2353546		Intermediate piece "G" 7/8-14-UNF
	◆ ★ ●	1	2353547		Intermediate piece "F" 11/16-16-UN
9		2	9910403		Cap nut
10		1	2343085		Bolt
11		1	2353611		Filter socket with seal
12		1	2353613		Spray gun body
13		2	43411		Actuating pins
14	◆ ★	1	364340		Seal, filter
15	◆	1	--		Filter insert, white (coarse), 50 mesh per inch *
	◆ ●	1	2315723		* Filter insert, red (fine), 200 mesh per inch – 10 pieces
	◆ ●	1	2315724		* Filter insert, blue (middle), 150 mesh per inch – 10 pieces
	◆ ●	1	2315725		* Filter insert, yellow (middle), 100 mesh per inch – 10 pieces
	◆ ●	1	2315726		* Filter insert, white (coarse), 50 mesh per inch – 10 pieces
	◆ ●	1	2365429		* Filter insert, green (coarse), 30 mesh per inch – 10 pieces
16a	◆ ★	1	--		Seal kit PT-HD GM1 metal → included with PROTEC Tip 556xxx
	◆ ●	1	2367857		Seal kit PT-HD GM1 metal – 5 pieces
	◆ ●	1	2353548		Seal kit PT-HD GM1 plastic – 5 pieces
16b	◆ ●	1	2371335		Seal
16c	◆ ●	1			
17a		1	2353549		Nozzle holder PT-HD GM1 → for Profi Tip HD 1006xxx and PROTEC Tip 556xxx
17b	●	1	2371338		Nozzle holder WAGNER Tip 7/8 UNF → for WAGNER Tip 1088xxx
17c	●	1	2371336		Anti-contact guard 7/8 UNF → for Standard Tip 90xxx (not for Standard Tip <i>plus</i>)
18		1	9992590		Loctite® 222
19		1	9992804		Loctite® 648
20	●	1	2353551		Service set GM1 with intermediate piece "G" 7/8-14-UNF (Pos 8)
	●	1	2356832		Service set GM1 with intermediate piece "F" 11/16-16-UN (Pos 8)

◆ = Wearing parts

★ = Included in service set

● = Not part of the standard equipment, but available as a special accessory

14 DECLARATION OF CONFORMITY

Herewith we declare that the supplied version of:

GM 1-350

GM 1-530

complies with the following guidelines:

SI 2008/1597
SI 2016/1107

Applied standards, in particular:

BS EN ISO 12100:2010	BS EN 1127-1:2019
BS EN 1953:2013	BS EN ISO 80079-36:2016
BS EN ISO 13732-1:2008	
BS EN 14462:2015	

Applied national technical standards and specifications, in particular:

--	
----	--

Identification: UK CA  II 2 G T6 X

UK Declaration of Conformity

The UK Declaration of Conformity is enclosed with this product. If needed, further copies can be ordered through your WAGNER dealer by specifying the product name and serial number.

Order number: 2355332

VERSION 07/2017

ORDER NUMBER DOC 2439572

GM 1-350/530

OPERATING MANUAL





United Kingdom

Wagner Spraytech (UK) Ltd.
Innovation Centre
Silverstone Park Silverstone

NN12 8GX Northants

Telefon +44 (0) 1327 368 410

E-Mail enquiries@wagner-group.com

Order No. 2439572

Version 07/2017

Germany

J. WAGNER GmbH
Otto-Lilienthal-Str. 18
Postfach 1120

88677 Markdorf

Phone +49/ (0)7544 / 5050

Telefax +49/ (0)7544 / 505200

E-mail ts-liquid@wagner-group.com

Switzerland

Wagner International AG
Industriestrasse 22

9450 Altstätten

Phone +41/ (0)71 / 757 2211

Telefax +41/ (0)71 / 757 2222

More contact addresses:

www.wagner-group.com

Subject to changes without notice