



AA4400M[□] AIR-ASSIST AIRLESS SPRAY GUN



FLAT TIP



REVERSIBLE TWIST TIP

The following instructions provide the necessary information for the proper operation and preventive maintenance of the Binks AA4400M Air-Assist Airless Spray Gun. Please read and understand all information in this document in order to get the maximum performance from your new AA4400M spray gun.

In the AA4400M spray gun, the paint or other material to be sprayed is pre-atomized and forced through the

carbide tip by the typical 110-262 bar [1,600-3,800 psi] fluid pressure (with capabilities up to 303 bar [4,400 psi]). As a result of the pre-atomizing, the final shaping air supplied by the air cap produces an exceptionally fine and even spray pattern. The result of this spray pattern is an even finish that lends itself to products that need an exceptionally fine finish with reduced overspray and VOC emissions.

SPECIFICATIONS:

Maximum Fluid Pressure:	303 bar [4,400 psi]
Maximum Air Pressure:	6.8 bar [100 psi]
Gun Body:	Forged Aluminum
Fluid Path:	Stainless Steel
Fluid Seat:	Tungsten Carbide Seat
Fluid Inlet Size:	1/4" NPS(m) Thread
Air Inlet Size:	1/4" BSP/NPS(m) Thread
Gun Weight:	490 g [17.28 oz.] (without Tip, Aircap, Guard)

1 bar [15 psi] is the maximum inlet air pressure for HVLP (1 bar [15 psi] max. for HVLP twist tip cap), or use 1.4-2.8 bar [20-40 psi] inlet air pressure for LVMP. The HVLP flat tip and twist tip air caps consume 230 L/m [8.3 SCFM] air at their respective maximum inlet air pressures. The LVMP flat tip and twist tip air caps consume 368 L/m [13 SCFM] at 2.1 bar [30 psi] inlet air pressure.

Product Description/Object of Declaration: Air Assist Guns - 0909-xxxx-x

This Product is designed for use with: Solvent and Water based Materials

Suitable for use in hazardous area: Zone 1

Protection Level: II 2 G X

Notified body details and role: Element Materials Technology. WN8 9PN UK
Lodging of Technical file

**This Declaration of Conformity
/incorporation is issued under the sole
responsibility of the manufacturer:** Carlisle Fluid Technologies,
320 Phillips Ave.,
Toledo, OH 43612

EU Declaration of Conformity



The object of the declaration described above is in conformity with the relevant Union harmonisation legislation:

Machinery Directive 2006/42/EC
ATEX Directive 2014/34/EU

by complying with the following statutory documents and harmonized standards:

EN ISO 12100:2010 Safety of Machinery - General Principles for Design

EN 13463-1:2009 Non electrical equipment for use in potentially explosive atmospheres - Basic methods and requirements

EN 1953:2013 Atomising and spraying equipment for coating materials. Safety requirements

The object of the declaration described above is in conformity with the relevant Union harmonisation legislation: Directive 94/9/EC (until April 19th, 2016) and Directive 2014/34/EU (from April 20th, 2016)

Providing all conditions of safe use / installation stated within the product manuals have been complied with and also installed in accordance with any applicable local codes of practice.

Signed for and on behalf of
Carlisle Fluid Technologies:

DJ Hasselschwert
14-Apr-16

4-3193R-1

WARNING

The spray gun must be earthed to dissipate any electrostatic charges which may be created by fluid or air flows. This can be achieved through the spray gun mounting, or conductive air/fluid hoses. Electrical bond from the spray gun to earth should be checked and a resistance of less than 10⁶ Ohms is required.

In this part sheet, the words **WARNING**, **CAUTION** and **NOTE** are used to emphasize important safety information as follows:

⚠ WARNING
Hazards or unsafe practices which could result in severe personal injury, death or substantial property damage.

⚠ CAUTION
Hazards or unsafe practices which could result in minor personal injury, product or property damage.

NOTE
Important installation, operation or maintenance information.

WARNING

READ THE FOLLOWING WARNINGS BEFORE USING THIS EQUIPMENT.



MEDICAL ALERT

Any injury caused by high pressure liquid can be serious. If you are injured or even suspect an injury:

- a) Go to an emergency room immediately.
- b) Tell the doctor you suspect an injection injury.
- c) Show the doctor this medical information or the medical alert card provided with your airless spray equipment.
- d) Tell the doctor what kind of fluid you were spraying or dispensing.
- e) Refer to the Safety Data Sheet for specific information.



GET IMMEDIATE MEDICAL ATTENTION

To prevent contact with the fluid, please note the following:

- a) Never point the gun/valve at anyone or any part of the body.
- b) Never put hand or fingers over the spray tip.
- c) Never attempt to stop or deflect fluid leaks with your hand, body, glove or rag.
- d) Always have the tip guard on the spray gun before spraying.
- e) Always ensure that the gun trigger safety operates before spraying.
- f) Always lock the gun trigger safety when you stop spraying.



READ THE MANUAL

Before operating finishing equipment, read and understand all safety, operation and maintenance information provided in the operation manual.



INSPECT THE EQUIPMENT DAILY

Inspect the equipment for worn or broken parts on a daily basis. Do not operate the equipment if you are uncertain about its condition.



OPERATOR TRAINING

All personnel must be trained before operating finishing equipment.



NEVER MODIFY THE EQUIPMENT

Do not modify the equipment unless the manufacturer provides written approval.



EQUIPMENT MISUSE HAZARD

Equipment misuse can cause the equipment to rupture, malfunction, or start unexpectedly and result in serious injury.



STATIC CHARGE

Fluid may develop a static charge that must be dissipated through proper grounding of the equipment, objects to be sprayed and all other electrically conductive objects in the dispensing area. Improper grounding or sparks can cause a hazardous condition and result in fire, explosion or electric shock and other serious injury.



DE-ENERGIZE, DEPRESSURIZE, DISCONNECT AND LOCK OUT ALL POWER SOURCES DURING MAINTENANCE

Failure to De-energize, disconnect and lock out all power supplies before performing equipment maintenance could cause serious injury or death.



PINCH POINT HAZARD

Moving parts can crush and cut. Pinch points are basically any areas where there are moving parts.



HIGH PRESSURE CONSIDERATION

High pressure can cause serious injury. Relieve all pressure before servicing. Spray from the spray gun, hose leaks, or ruptured components can inject fluid into your body and cause extremely serious injury.



WEAR RESPIRATOR

Toxic fumes can cause serious injury or death if inhaled. Wear a respirator as recommended by the fluid and solvent manufacturer's Safety Data Sheet.



PRESSURE RELIEF PROCEDURE

Always follow the pressure relief procedure in the equipment instruction manual.



TOXIC FLUID & FUMES

Hazardous fluid or toxic fumes can cause serious injury or death if splashed in the eyes or on the skin, inhaled, injected or swallowed. LEARN and KNOW the specific hazards or the fluids you are using.



KEEP EQUIPMENT GUARDS IN PLACE

Do not operate the equipment if the safety devices have been removed.



NOISE HAZARD

You may be injured by loud noise. Hearing protection may be required when using this equipment.



KNOW WHERE AND HOW TO SHUT OFF THE EQUIPMENT IN CASE OF AN EMERGENCY



WEAR SAFETY GLASSES

Failure to wear safety glasses with side shields could result in serious eye injury or blindness.



PROJECTILE HAZARD

You may be injured by venting liquids or gases that are released under pressure, or flying debris.

**IT IS THE RESPONSIBILITY OF THE EMPLOYER TO PROVIDE THIS INFORMATION TO THE OPERATOR OF THE EQUIPMENT.
FOR FURTHER SAFETY INFORMATION REGARDING BINKS AND DEVLBISS EQUIPMENT, SEE THE GENERAL EQUIPMENT SAFETY BOOKLET (77-5300).**

SPRAY GUN SET-UP

NOTE

Before proceeding, make sure trigger lock is engaged.

1. Connect your high-pressure fluid hose to the gun fluid inlet and tighten securely.
2. Connect your air hose to the gun air connection and tighten securely.
3. Slowly increase air to the pump to obtain a fluid pressure at the gun's lower end of the pressure range. A typical starting fluid pressure is 17 bar [250 psi]. Actual starting pressure points may be higher or lower than 17 bar [250 psi] and depend on the setup including the type of pump used, the type of material sprayed, and the spray gun itself.
4. Using the control knob on the air regulator, set the air pressure at zero.
5. To test the spraying pattern, spray a piece of wood or cardboard with a fast pass about one foot away from the surface. The results of the test will allow you to determine the uniformity of the particle size and spraying pattern.
6. If the spraying pattern develops tails or is not uniform, gradually increase the air pressure as necessary to develop a uniform spraying pattern. 1 bar [14 psi] is the maximum inlet air pressure for HVLP (1 bar [15 psi] max. for HVLP twist tip cap), or use 1.4-2.8 bar [20-40 psi] inlet air pressure for LVMP. **The HVLP flat tip and twist tip air caps consume 230 L/m [8.3 SCFM] air at their respective maximum inlet air pressures. The LVMP flat tip and twist tip air caps consume 368 L/m [13 SCFM] at 2.1 bar [30 psi] inlet air pressure.** The air is used to assist the atomization of the coating.
7. If the quality of spray is acceptable, begin spraying. If the spraying rate is too slow to keep up with the production line speed, or if the quantity of material sprayed is inadequate for acceptable coverage, gradually increase the fluid pressure in 3.4 bar [50 psi] increments using the fluid regulator control knob. However, note that as the fluid pressure increases, more air is needed to eliminate the tails.

Consistency in spraying can be increased across spray gun operators and similar spraying jobs by developing pressure standardization charts. Repeat step 6 until the required material coverage and spraying speed are achieved. If the maximum fluid pressure is reached before the required material coverage and spraying speed are achieved, you may need to switch to a larger fluid tip.

TYPICAL HOOK-UP

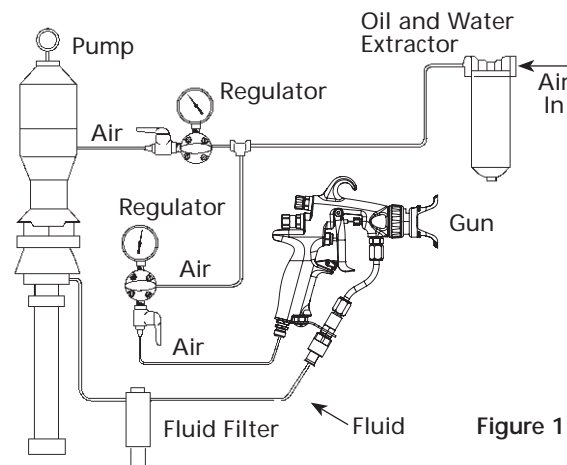

Figure 1

Fan pattern adjustment: turn knob counterclockwise to decrease pattern; clockwise to increase pattern (Fig. 2).

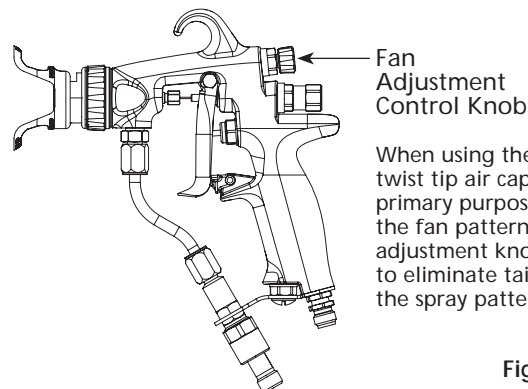

Figure 2

NOTE

For HVLP spray, fan adjustment feature requires 1 bar [14 psi] max. of air inlet pressure (1 bar [15 psi] max. for HVLP twist tip.) For LVMP spray, fan adjustment requires approximately 1.4-2.8 bar [20-40 psi] of air inlet pressure. Higher fluid pressure requires higher air inlet pressures to accommodate pattern adjustment.

NOTE

Do not hang gun by trigger. This will cause needle damage or malfunction.

FLUID TIP SELECTION

Factors to consider in selecting a fluid tip for an air-assist airless spray gun include (1) the size of the parts being sprayed; (2) the production line speed; (3) the material flow rate and film thickness; (4) the viscosity of the material applied; (5) the type of material applied; and (6)

the quality of atomization of the coating required. The selection of a fluid tip necessary to perform a specific spraying job is best determined through a combination of experimentation and expert advice from your material and equipment suppliers.

FLUID HOSES

Air-assist airless spray guns operate at fluid pressures higher than operating pressures of air spray guns. As a result, when operating an air-assist airless spray gun, it is

critical to select the appropriate fluid hose that is rated for the pressure range at which the airless gun is operated.

TROUBLESHOOTING DEFECTIVE SPRAY PATTERNS

⚠ CAUTION

Always engage trigger lock and relieve fluid pressure before servicing gun.

The following procedure summarizes the steps that an operator must immediately take when the first signs of a defective spray pattern emerge.

1. Check the external portion of the fluid tip for material buildup. If buildup has occurred, secure the gun trigger safety switch and clean the gun fluid tip with a non-metal soft brush.
2. If the spray pattern exhibits signs of tails at the top or bottom ends of the pattern, increase the air pressure gradually until the tails disappear.
3. If increasing air pressure does not dissipate the tails, the fluid tip may be worn and may need to be

replaced. Another sign of the need to replace a worn tip is a gradual decline in spraying pattern width.

4. If cleaning or replacing the fluid tip does not dissipate the tails; the spraying defect is most likely due to the material temperature and/or viscosity.
5. If pattern pulsation or blinking occurs, check the pressure regulators, all downstream regulators, and the pump. These may require further adjustment or even repairs.

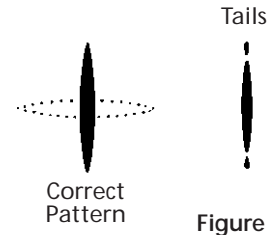

GENERAL TROUBLESHOOTING

(Refer to page 12 when referencing part numbers in brackets.)



PROBLEM	CAUSE	ACTION
Fluid leaking from through the seal	Worn seal or needle shaft. Loose needle seal.	Replace needle assembly (18). Tighten packing nut gently until leak stops.
Fluid leaking from the front of the gun	Needle ball worn or damaged. Worn seat assembly.	Replace needle assembly (18). Replace fluid seat (3/3A).
Fluid in air passages	Spray tip seal leaking. Leaking around fluid seat.	Tighten air cap/nozzle guard assembly (7) Replace carbide tip assembly (5/5A). Tighten or replace fluid seat (3/3A).
Slow fluid shut off	Fluid buildup on needle assembly.	Clean or replace needle assembly (18).
No fluid output when triggered	Tip orifice plugged. Needle is damaged or broken. Fluid filter or fluid hose plugged.	For flat tip: Turn off fluid supply. Relieve pressure into a closed earth-grounded container. Engage trigger safety. Remove air cap/nozzle guard assembly (6) and the carbide tip (5). Clean or replace carbide tip assembly (5). For twist tip: Rotate twist tip (5A) in aircap (6A) and spray into a closed-grounded container to try clear tip of any debris. If that fails to unplug the tip then remove, clean and replace twist tip. Turn off fluid supply. Relieve pressure into a closed-grounded container. Remove trigger (10). Replace needle assembly (18) Turn off fluid supply. Relieve pressure into a closed-grounded container. Turn off air supply to pump and relieve fluid pressure with bypass valve. Engage trigger safety. Very slowly loosen the hose connection at the gun to relieve any pressure in hose. Remove hose and clear obstruction. NOTE: When replacing filter, use two wrenches—one to hold tube (11) in place and prevent twisting, and the other to remove nut (14). Only tighten nut (14) from 12-15 N-m [9 - 11 ft.-lbs.]

IMPORTANT REGULATORY NOTE

The AA4400M Air-Assist H.V.L.P. hand spray gun combines the proven efficiency of the Binks compliant spray guns with air-assist atomization to yield a reliable, carefully engineered compliant spray gun. With 25' of 5/16" I.D. air hose and regulator set at only 1.4 bar [20 psi] the compliant air cap registers 0.7 bar [10 psi] of atomization air to shape and soften the spray pattern. The AA4400M air-assist H.V.L.P. gun operates at high transfer efficiencies and fully complies with all government regulations for H.V.L.P. spray guns.

	Max. Fluid Input: 303 bar [4400 psi]
Max. static air pressure at regulator with 25' of hose to inlet:	1.4 bar [20 psi]
Max. Dynamic Gun Inlet Air Pressure:	1 bar [14 psi]
Gun Body:	Forged Aluminum Alloy
Fluid Path:	Stainless Steel and Tungsten Carbide / PEEK

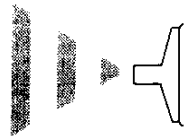
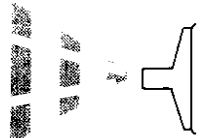
SPRAY PATTERN TROUBLESHOOTING

PROBLEM	CAUSE	ACTION
Fluttering Spray Pattern 	Insufficient fluid supply. Air in paint supply line. Attempting to "feather" (Partially trigger gun).	Adjust fluid regulator or fill fluid supply tanks. Check and tighten pump siphon hose connections, bleed air from paint line. Cannot feather with an AA4400M gun.
Striping Spray – Fingers 	Carbide tip partially plugged.	Clean or replace carbide tip assembly.
Irregular Pattern 	Fluid builds up on carbide tip, or tip partially plugged. On defective side of pattern, air horn holes are plugged.	Clean carbide tip. Clean air horn holes with solvent and a soft brush.
Pattern pushed to one side, same side of air cap gets dirty 	On defective side of pattern, air horn holes are plugged.	Clean air horn holes with solvent and a soft brush or toothpick.

AIR-ASSIST AIRLESS SPRAY GUN MAINTENANCE AND CLEANING

Maintenance of air-assist airless spray guns includes (1) fluid tip wear and replacement; (2) lubrication; and (3) cleaning of the gun.

FLUID TIP

Operating an air-assist airless spray gun with a worn fluid tip will result in increased usage of spraying material and therefore, HAP emissions. For example, an increase in the diameter of a tip from 0.38-0.53 mm [0.015-0.021"] due to wear can result in up to a 100 percent increase in material consumption and cost. To prevent waste in spraying material and non-value-adding costs, a maintenance schedule that includes fluid tip inspection and replacement must be established.

LUBRICATION

Proper lubrication is essential for optimum spray gun performance. Lubrication allows the equipment to operate easily and correctly. The spray gun should be lubricated after each cleaning. The points that need lubrication during the maintenance of air-assist airless spray guns include the fluid needle packing and trigger pivot point. Gun lube is used to lubricate the fluid needle packing and trigger pivot point.

 CAUTION
Never immerse the entire gun in solvent or thinners. Some gun parts will lose their lubricative film and wear more quickly. Additionally, solvents may carry impurities throughout the gun body and allow them to clog small air and fluid passages.

CLEANING

The following steps summarize the procedure for cleaning air-assist airless spray guns:

1. Turn off the atomizing air supply to the gun.
2. Turn off air supply to the pump and relieve fluid pressure. This may be accomplished by opening the bypass/priming valve, if so equipped.
3. Place the siphon (suction) tube into a solvent container. If pump is directly immersed in material, remove the pump and immerse it in a solvent container.

NOTE
Use only compatible solvents that are identified as approved for cleaning and wash-off use.

4. Place the gun trigger safety switch in the locked position.
5. Remove the fluid tip and place it in a closed solvent container.
6. Adjust the pump air supply regulator to its lowest level (counter-clockwise).
7. Place the gun trigger safety switch in the unlocked position.
8. Turn on the air supply to the pump and close the bypass/priming valve, if so equipped.
9. Slowly adjust the pump air supply regulator until the pump begins to cycle.
10. Trigger the gun into a closed container until the fluid runs clear.

 WARNING
Failure to reduce pump air supply pressure or to use a closed container can result in material "bounce-back". Material "bounce back" can cause injury and damage.

NOTE
During cleaning, the gun may only be sprayed into a closed container, never flush the gun into the air or spray booth.

CLEANING *(Continued)*

11. Using a rag dampened with solvent, wipe the exterior surface of the gun. Additionally, some solvents are prohibited from being used for cleaning. The operator must take care to use only approved cleaning solvents for equipment cleaning. These materials are clearly

labeled as approved for cleaning and wash off operations. If the operator has any question on selecting appropriate cleaning solvents, the operator should consult a supervisor or plant environmental staff.

REPLACING FLUID NOZZLE AND/OR FLUID NEEDLE ASSEMBLY

REASONS TO REPLACE NOZZLE AND/OR NEEDLE ASSEMBLY:

- A) Fluid leak through fluid nozzle.
- B) Slow shut off of fluid.
- C) No fluid when gun triggered.

CAUTION

Always ensure that all fluid and air pressure to the gun has been discharged before proceeding with any repairs.

REPLACING THE FLUID NOZZLE

CAUTION

Do not remove fluid tube when replacing the fluid nozzle.

1. Remove air cap along with spray tip. (See fig 4)
2. While fully depressing the trigger remove the fluid nozzle and gasket. (See fig 5)
3. Check baffle plate for wear. If worn replace with new part. (See fig 6)
4. While fully depressing the trigger install the new fluid nozzle and gasket. Torque fluid nozzle from 12-15 N-m [9-11 ft-lbs]. (See fig 5).
5. Replace the air cap along with spray tip (See fig 4)

REPLACING THE FLUID NEEDLE ASSEMBLY

1. Remove the trigger by removing the trigger screw and trigger nut. (See fig 7)
2. Completely unscrew needle packing nut. (See fig 8)
3. Unscrew blanking cap and remove the needle spring and pad. (See figs 9 & 10)
4. Ensure the spring pad has not been worn down and clean the spring of any debris. (See fig 11)
5. Remove the needle assembly. (See fig 12)
6. Insert new needle assembly and new spring if necessary. (See figs 12 & 10) Ensure the spring pad is attached to the spring.
7. Screw on blanking cap. (See fig 9)
8. Gently tighten needle packing nut. **DO NOT OVER TIGHTEN.** (See fig 8)
9. Replace trigger, trigger screw and trigger nut. (See fig 7)
10. Operate gun with fluid and adjust tightness of packing nut as necessary to prevent fluid leak. (See fig 8)



Fig. 4

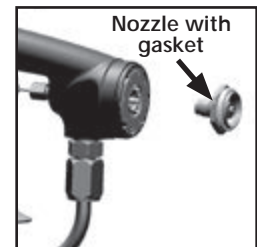

Fig. 5



Fig. 6



Fig. 7

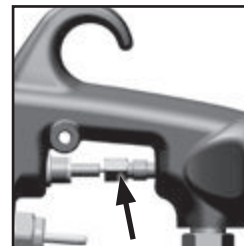

Fig. 8

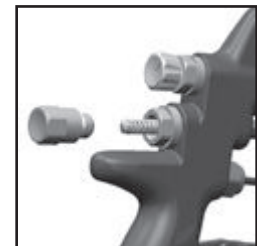

Fig. 9



Fig. 10



Fig. 11



Fig. 12

SERVICING AIR VALVE

REASONS TO SERVICE AIR VALVE:

- A) Air valve not functioning correctly (may need cleaning).
- B) Routine maintenance.
- C) Air leaks (advise replacement, see p8)

CAUTION

Always ensure that all fluid and air pressure to the gun has been discharged before proceeding with any repairs.

1. Remove trigger and fluid tube assembly. (See fig 13 & 14)
2. Unscrew air valve using 14 mm wrench. (See fig 15)
3. Remove air valve by gripping stem. (See fig 16)
4. Remove spring with spring pad. (See fig 17)
5. **DO NOT REMOVE REAR SEAL FROM GUN BODY.**
(See fig 18)
6. **DO NOT REMOVE PLASTIC CAGE FROM AIR VALVE BODY AS THIS MAY DAMAGE THE CAGE.** (See fig 19)
7. **CLEAN**
 - a. Remove all paint build up. (See fig 20)
 - b. The 4 poppet holes must be clear. (See fig 21)
 - c. Stem must be free to float in poppet. (See fig 22)
 - d. Stem must slide through cage bore with slight resistance (due to seal).
 - e. Rear seal must look clean and in position in the bore. (See fig 18)
 - f. If any of the above cannot be rectified, replace the air valve. (See Replacing Air Valve p8)
8. Replace spring ensuring the end with the plastic bearing pad goes in first. (See fig 17)
9. Insert air valve assembly into gun and carefully feed over the spring and through the rear seal. (See fig 23)
10. Tighten air valve assembly using fingers first, and then tighten with 14mm wrench. Torque from 24-30 N-m [18-22 ft-lbs]. (See fig 24)
11. Replace the fluid tube and trigger. (See figs 14 & 13)
12. If there is an air leak through the gun, the air valve may need replacing. (See Replacing Air Valve p8)

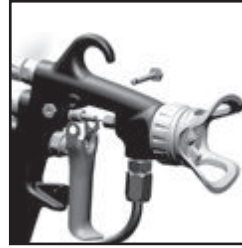

Fig. 13



Fig. 14



Fig. 15



Fig. 16



Fig. 17

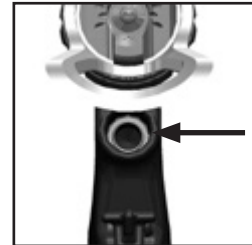

Fig. 18

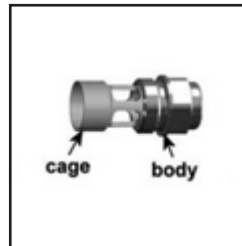

Fig. 19

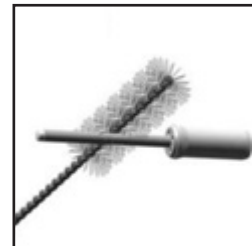

Fig. 20



Fig. 21

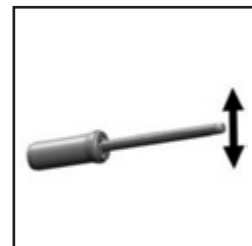

Fig. 22



Fig. 23

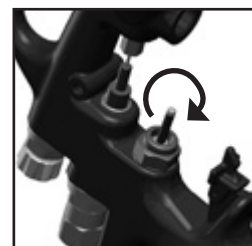

Fig. 24

REPLACING AIR VALVE

REASONS TO REPLACE AIR VALVE:

- A) Air leak through the gun.
- B) Air valve not operating correctly.

⚠ CAUTION

Always ensure that all fluid and air pressure to the gun has been discharged before proceeding with any repairs.

1. Remove trigger and fluid tube assembly. (See figs 25 & 26)
2. Unscrew air valve using 14 mm wrench. (See fig 27)
3. Remove air valve by gripping the stem. (See fig 28)
4. Remove spring with spring pad. (See fig 29)
5. Hook out rear seal using Service Tool. (See figs 30 & 31)
6. Clean air valve bores in gun body with the brush supplied in the kit.
7. Place new rear seal onto Service tool; grooves must fit in service tool form. (See fig 32)
8. Push rear seal firmly into hole up to shoulder, using Service tool. (See figs 33 & 34)
9. Insert new spring, ensuring the end with the plastic bearing pad goes in first. (See fig 29)
10. Insert air valve assembly into gun and carefully feed over the spring and through the rear seal. (See fig 35)
11. Tighten air valve assembly using fingers first, then tighten with 14 mm wrench. Torque from 24-30 N-m [18 to 22 ft-lbs]. (See fig 36)
12. Replace fluid tube and trigger. (See figs 26 & 25)

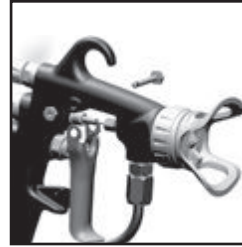

Fig. 25



Fig. 26



Fig. 27

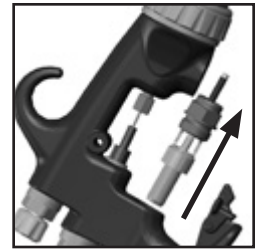

Fig. 28



Fig. 29



Fig. 30



Fig. 31

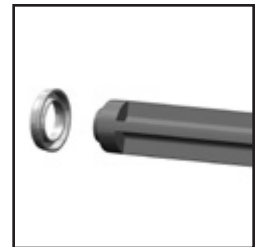

Fig. 32



Fig. 33



Fig. 34



Fig. 35



Fig. 36

TIP GUARD INSTALLATION

REASON TO INSTALL TIP GUARD:

To replace broken tip guard.

⚠ WARNING

For pressures over 69 bar [1000 psi] the tip guard must be in place for added protection against skin injection.

⚠ CAUTION

Always ensure that all fluid and air pressure to the gun has been discharged before proceeding with any repairs.

INSTRUCTIONS ARE VALID FOR BOTH FLAT TIP GUARD AND TWIST TIP GUARD:

1. Disconnect all fluid and air hoses from the gun.
2. Insert the gun into a clamping vise with fluid nozzle facing directly upwards. (See fig 37) Gun should be securely clamped at the upper portion of the gun handle.
3. Assemble air cap and air cap ring together – **less spray tip and plastic tip guard.** (See fig 38)
4. Install the air cap and air cap ring assembly onto the gun until it is fully hand tightened. (See fig 39)
5. Slip on the plastic tip guard onto the air cap in proper orientation. (See fig 40)
6. Place round bar screwdriver between open sections of the plastic guard and push down with even pressure on both sides of the plastic guard. (See fig 41)
7. The guard should snap into air cap groove securely. (See fig 42)
8. The aircap can now be removed to install the appropriate tip for use.



Fig. 37

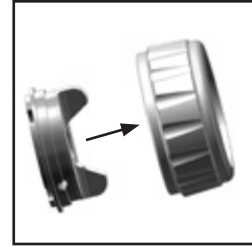

Fig. 38



Fig. 39

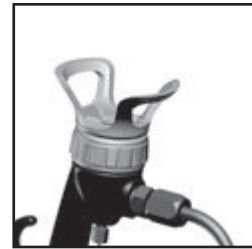

Fig. 40

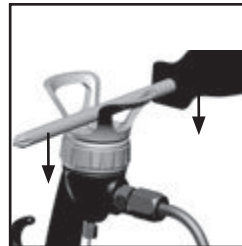
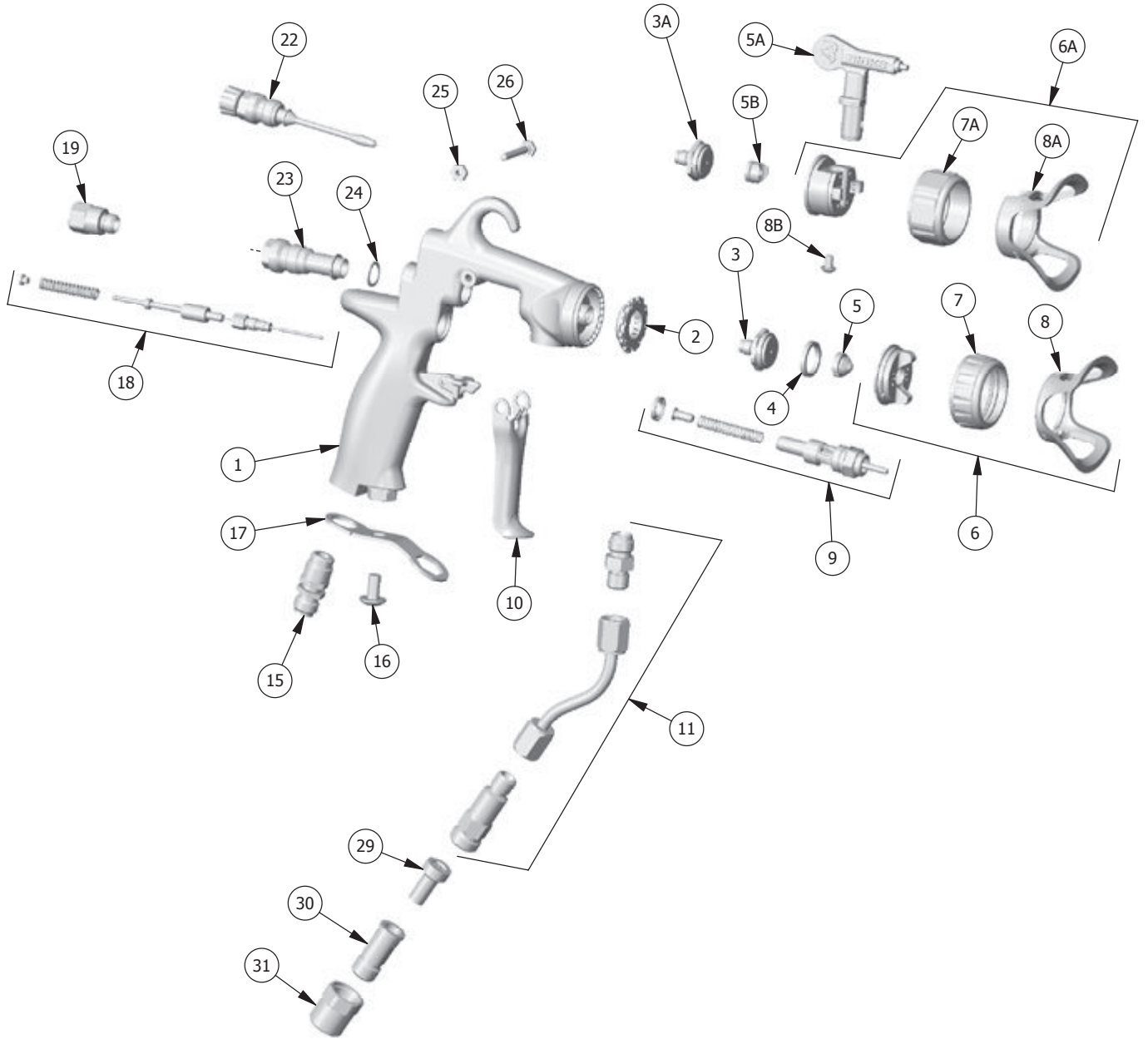

Fig. 41



Fig. 42

AA4400M AIR-ASSIST AIRLESS SPRAY GUN



AA4400M AIR-ASSIST AIRLESS SPRAY GUN

PARTS LIST

When ordering, please specify Part No. (Not all Part Nos. are available for purchasing.)

Refer to page 10 when referencing Item Nos.

ITEM NO.	PART NO.	DESCRIPTION	QTY.	ITEM NO.	PART NO.	DESCRIPTION	QTY.
1	—	GUN BODY	1	9	SN-402-K	AIR VALVE ASSEMBLY	1
2	SPA-71-K5	BAFFLE PLATE (KIT OF 5)	1	10	— ▲	TRIGGER	1
FLAT TIP COMPONENTS				11	54-5780	FLUID TUBE ASSEMBLY	1
3	54-5799-K ⚡	FLUID SEAT (4400PSI)	1	15	SN-9-K3	AIR INLET FITTING 1/4" NPS (KIT OF 3)	1
		(TUNGSTEN CARBIDE)		16	— ●	FILTER BRACKET SCREW	1
4	SPA-98-K5	GASKET (KIT OF 5)	1	17	— ●	FILTER BRACKET	1
5	114-XXXXX ■	FLAT TIP (FINE FINISH TIPS 9-XXXX-F)	1	18	54-5826	FLUID NEEDLE ASSEMBLY KIT (4400PSI)	1
6	54-5878-K ▼	FLAT TIP HVLP AIRCAP	1	19	54-5850	BLANKING NEEDLE NUT	1
		(FLAT TIP LVMP AIRCAP 54-5797-K)		22	54-5815	SPREADER VALVE ASSEMBLY	1
		(AA-10 FLAT TIP HVLP AIRCAP 54-5890-K)		23	— #	BODY BUSHING	1
		(FLAT TIP AIRCAP HVLP 54-5795)		24	— #	BODY BUSHING GASKET	1
7	54-5852	RETAINING RING	1	25	— ▲	TRIGGER NUT	1
8	54-5794 ○	FLAT TIP GUARD	1	26	— ▲	TRIGGER SCREW	1
TWIST TIP COMPONENTS				29	54-1835	100 MESH DISC FILTER (1 PIECE)	1
3A	54-5832-K ⚡	TWIST TIP FLUID SEAT (4400PSI)	1			(60 MESH FILTER 54-1836)	
		(TUNGSTEN CARBIDE)		30	— *	DISC FILTER HOUSING	1
5A	9-XXX-75 ■	TWIST TIP	1	31	— *	DISC FILTER RETAINING NUT	1
5B	54-7539-K2	TWIST TIP BRACE (KIT OF 2)	1	<p>▼ All aircap kits are pre-assembled with Retaining ring and appropriate tip guard. When switching from flat tip to twist tip, or vice versa, be sure to order correct fluid seat (3/3A). For twist tip, item 5B will also be needed.</p> <p>■ Refer to page 12 for available tip sizes. When purchasing twist tip, discard packaged brace/seal and use Item 5B only.</p> <p>⚡ Pre-assembled with gasket SPA-98.</p> <p>▲ Available as part of kit 54-5835.</p> <p>● Available as part of kit 54-5827.</p> <p># Available as part of kit 54-5829.</p> <p>○ Mandatory for operating pressures above 69 bar [1000 psi].</p> <p>* Available as part of kit 54-4726-K. Order filter (29) separately.</p>			
6A	54-5924-K ▼	TWIST TIP HVLP AIRCAP	1				
		(TWIST TIP LVMP AIRCAP 54-5925-K)					
7	54-5928	RETAINING RING	1				
8A	54-5921 ○	TWIST TIP GUARD	1				
8B	54-5930 ○	TWIST TIP GUARD SCREW	1				

ACCESSORIES

FITTINGS

54-4976-K3	3-Pack 1/4" NPT(f) x 3/8" O.D. Push-In Tube Fitting (optional)
72-2332	Fluid Inlet Swivel (1/4"m x 1/4"f)

FLUID FILTER

54-1835	100 Mesh (Disc) Filter
54-1836	60 Mesh (Disc) Filter

HVLP AIRCAP TEST KITS

54-5882-K	Flat Tip HVLP Aircap Test Kit (Incl Gauge) for 54-5878 air cap
54-5836-K	Flat Tip HVLP Aircap Test Kit (Incl Gauge) for 54-5795 air cap
54-5837-K	Twist Tip HVLP Aircap Test Kit (Incl Gauge)

TEST GAUGES

54-5327	HVLP Test Gauge
---------	-----------------

TWIST TIP SELECTION CHARTS

Fan width based on 152 bar [2200 psi] with latex paint 305 mm [12"] from surface. Actual results may vary, depending on material viscosity.

PART NUMBER	DESCRIPTION	ORIFICE	FAN WIDTH (IN.)	GPM CAPACITY @ 152 BAR [2200 PSI]
9-307-75	TWIST TIP	.007	6	0.05
9-309-75	TWIST TIP	.009	6	0.09
9-409-75	TWIST TIP	.009	8	0.09
9-509-75	TWIST TIP	.009	10	0.09
9-211-75	TWIST TIP	.011	4	0.12
9-311-75	TWIST TIP	.011	6	0.12
9-411-75	TWIST TIP	.011	8	0.12
9-511-75	TWIST TIP	.011	10	0.12
9-611-75	TWIST TIP	.011	12	0.12
9-213-75	TWIST TIP	.013	4	0.18
9-313-75	TWIST TIP	.013	6	0.18
9-413-75	TWIST TIP	.013	8	0.18
9-513-75	TWIST TIP	.013	10	0.18
9-613-75	TWIST TIP	.013	12	0.18
9-713-75	TWIST TIP	.013	14	0.18
9-215-75	TWIST TIP	.015	4	0.24
9-315-75	TWIST TIP	.015	6	0.24
9-415-75	TWIST TIP	.015	8	0.24
9-515-75	TWIST TIP	.015	10	0.24
9-615-75	TWIST TIP	.015	12	0.24
9-715-75	TWIST TIP	.015	14	0.24
9-217-75	TWIST TIP	.017	4	0.31
9-317-75	TWIST TIP	.017	6	0.31
9-417-75	TWIST TIP	.017	8	0.31
9-517-75	TWIST TIP	.017	10	0.31
9-617-75	TWIST TIP	.017	12	0.31
9-717-75	TWIST TIP	.017	14	0.31
9-419-75	TWIST TIP	.019	8	0.38
9-519-75	TWIST TIP	.019	10	0.38
9-619-75	TWIST TIP	.019	12	0.38
9-421-75	TWIST TIP	.021	8	0.47
9-521-75	TWIST TIP	.021	10	0.47
9-621-75	TWIST TIP	.021	12	0.47
9-523-75	TWIST TIP	.023	10	0.57
9-623-75	TWIST TIP	.023	12	0.57
9-525-75	TWIST TIP	.025	10	0.67
9-625-75	TWIST TIP	.025	12	0.67
9-627-75	TWIST TIP	.027	12	0.74
9-631-75	TWIST TIP	.031	12	1.03
9-435-75	TWIST TIP	.035	8	1.31
9-635-75	TWIST TIP	.035	12	1.31

FINE FINISH FLAT TIP SELECTION CHARTS

Fan width based on 69 bar [1000 PSI] with water 305 mm [12"] from surface. Actual results may vary, depending on material viscosity.

PART NUMBER	DESCRIPTION	ORIFICE	FAN WIDTH (IN.)	GPM CAPACITY @ 34 BAR [500 PSI] WATER
9-0909-F	FINE FINISH TIP	0.009	9	0.039
9-0911-F	FINE FINISH TIP	0.009	11	0.039
9-1109-F	FINE FINISH TIP	0.011	9	0.06
9-1111-F	FINE FINISH TIP	0.011	11	0.06
9-1113-F	FINE FINISH TIP	0.011	13	0.06
9-1115-F	FINE FINISH TIP	0.011	15	0.06
9-1309-F	FINE FINISH TIP	0.013	9	0.09
9-1311-F	FINE FINISH TIP	0.013	11	0.09
9-1313-F	FINE FINISH TIP	0.013	13	0.09
9-1315-F	FINE FINISH TIP	0.013	15	0.09
9-1509-F	FINE FINISH TIP	0.015	9	0.12
9-1511-F	FINE FINISH TIP	0.015	11	0.12
9-1513-F	FINE FINISH TIP	0.015	13	0.12
9-1515-F	FINE FINISH TIP	0.015	15	0.12
9-1517-F	FINE FINISH TIP	0.015	17	0.12
9-1709-F	FINE FINISH TIP	0.017	9	0.16
9-1711-F	FINE FINISH TIP	0.017	11	0.16
9-1713-F	FINE FINISH TIP	0.017	13	0.16
9-1715-F	FINE FINISH TIP	0.017	15	0.16
9-1717-F	FINE FINISH TIP	0.017	17	0.16

STANDARD FLAT TIP SELECTION CHARTS

Fan width based on 69 bar [1000 PSI] with water 305 mm [12"] from surface. Actual results may vary, depending on material viscosity.

PART NUMBER	DESCRIPTION	ORIFICE	FAN WIDTH (IN.)	GPM CAPACITY @ 34 BAR [500 PSI] WATER
114-00704	TIP ASSEMBLY	.007	4	.028
114-00706	TIP ASSEMBLY	.007	6	.028
114-00708	TIP ASSEMBLY	.007	8	.028
114-00902	TIP ASSEMBLY	.009	2	.039
114-00906	TIP ASSEMBLY	.009	6	.039
114-00908	TIP ASSEMBLY	.009	8	.039
114-00910	TIP ASSEMBLY	.009	10	.039
114-00912	TIP ASSEMBLY	.009	12	.039
114-01104	TIP ASSEMBLY	.011	4	.060
114-01106	TIP ASSEMBLY	.011	6	.060
114-01108	TIP ASSEMBLY	.011	8	.060
114-01110	TIP ASSEMBLY	.011	10	.060
114-01112	TIP ASSEMBLY	.011	12	.060
114-01114	TIP ASSEMBLY	.011	14	.060
114-01304	TIP ASSEMBLY	.013	4	.090
114-01306	TIP ASSEMBLY	.013	6	.090
114-01308	TIP ASSEMBLY	.013	8	.090
114-01310	TIP ASSEMBLY	.013	10	.090
114-01312	TIP ASSEMBLY	.013	12	.090
114-01314	TIP ASSEMBLY	.013	14	.090
114-01316	TIP ASSEMBLY	.013	16	.090
114-01506	TIP ASSEMBLY	.015	6	.120
114-01508	TIP ASSEMBLY	.015	8	.120
114-01510	TIP ASSEMBLY	.015	10	.120
114-01512	TIP ASSEMBLY	.015	12	.120
114-01514	TIP ASSEMBLY	.015	14	.120
114-01516	TIP ASSEMBLY	.015	16	.120
114-01518	TIP ASSEMBLY	.015	18	.120
114-01706	TIP ASSEMBLY	.017	6	.160
114-01708	TIP ASSEMBLY	.017	8	.160
114-01710	TIP ASSEMBLY	.017	10	.160
114-01712	TIP ASSEMBLY	.017	12	.160
114-01714	TIP ASSEMBLY	.017	14	.160
114-01716	TIP ASSEMBLY	.017	16	.160
114-01718	TIP ASSEMBLY	.017	18	.160
114-01906	TIP ASSEMBLY	.019	6	.190
114-01908	TIP ASSEMBLY	.019	8	.190
114-01910	TIP ASSEMBLY	.019	10	.190
114-01912	TIP ASSEMBLY	.019	12	.190
114-01914	TIP ASSEMBLY	.019	14	.190
114-01916	TIP ASSEMBLY	.019	16	.190
114-01918	TIP ASSEMBLY	.019	18	.190
114-02110	TIP ASSEMBLY	.021	10	.240
114-02112	TIP ASSEMBLY	.021	12	.240
114-02114	TIP ASSEMBLY	.021	14	.240
114-02116	TIP ASSEMBLY	.021	16	.240
114-02118	TIP ASSEMBLY	.021	18	.240
114-02410	TIP ASSEMBLY	.024	10	.310
114-02412	TIP ASSEMBLY	.024	12	.310
114-02414	TIP ASSEMBLY	.024	14	.310
114-02416	TIP ASSEMBLY	.024	16	.310
114-02418	TIP ASSEMBLY	.024	18	.310
114-02710	TIP ASSEMBLY	.027	10	.385
114-02712	TIP ASSEMBLY	.027	12	.385
114-02714	TIP ASSEMBLY	.027	14	.385
114-02716	TIP ASSEMBLY	.027	16	.385
114-02718	TIP ASSEMBLY	.027	18	.385

TWIST TIP NOTE

When switching from flat tip to twist tip, increase pattern size by 51 mm [2 inches] and use air adjustment to turn down to desired size.

FULL GUN ASSEMBLIES

AA4400M HVLP FLAT TIP GUN ASSEMBLY (NO TIP INCL.)	0909-4400-HF0000
AA4400M HVLP FLAT TIP GUN WITH AA-10 AIRCAP (NO TIP INCL.)	0909-4400-10000
AA4400M LVMP FLAT TIP GUN ASSEMBLY (NO TIP INCL.)	0909-4400-LF000
AA4400M HVLP TWIST TIP GUN ASSEMBLY (NO TIP INCL.)	0909-4400-HT0000

DESCRIPTION	ASS'Y NUMBER
AA4400M LVMP TWIST TIP GUN ASSEMBLY (NO TIP INCL.)	0909-4400-LT0000

NOTES

NOTES

WARRANTY POLICY

This product is covered by Carlisle Fluid Technologies materials and workmanship limited warranty. The use of any parts or accessories, from a source other than Carlisle Fluid Technologies, will void all warranties. Failure to reasonably follow any maintenance guidance provided may invalidate any warranty.

For specific warranty information please contact Carlisle Fluid Technologies.

For technical assistance or to locate an authorized distributor, contact one of our international sales and customer support locations.

Region	Industrial / Automotive	Automotive Refinishing
Americas	Tel: 1-800-992-4657 Fax: 1-888-246-5732	Tel: 1-800-445-3988 Fax: 1-800-445-6643
Europe, Africa, Middle East, India	Tel: +44 (0)1202 571 111 Fax: +44 (0)1202 573 488	
China	Tel: +8621-3373 0108 Fax: +8621-3373 0308	
Japan	Tel: +81 45 785 6421 Fax: +81 45 785 6517	
Australia	Tel: +61 (0) 2 8525 7555 Fax: +61 (0) 2 8525 7575	

For the latest information about our products, visit www.carlisleleft.com

Carlisle Fluid Technologies is a global leader in innovative finishing technologies. Carlisle Fluid Technologies reserves the right to modify equipment specifications without prior notice.

BGK, Binks, DeVilbiss, Hosco, MS, and Ransburg are all registered trademarks of Carlisle Fluid Technologies, Inc.

©2021 Carlisle Fluid Technologies, Inc.
All rights reserved.

